

CNC ROUTER CUTTERS & CHUCKS

TOOLBOX

Darbagaldi & Instrumenti

www.TOOLBOX.lv

info@toolbox.lv

PRODUCTS	PAGE
Kinetic Dust Extractor	248
CNC Chucks	249~252
Precision Collets	252-253
MK2 Chucks	254
HSK Chucks for Grooving Blade	254-255
Cutter Arbor	256
Universal Assembly Supports for Chucks	256
DLCS Coating Solid Carbide Spiral Bits	257
Solid Carbide Spiral Bits	258~268
Solid Surface and Fiberglass Bits	269
CNC DP Straight Cutters	270~274
CNC Carbide Cutters	275~278
CNC Profiled Cutters	279~283
Slot & Mortise Bits	284~290

TOOLBOX

Darbagaldi & Instrumenti

www.TOOLBOX.lv

info@toolbox.lv





992 Removes MDF & Chipboard dust from the workpiece

	DESCRIPTION	D mm		ORDER NO.
	Kinetic Dust Extractor for chucks with ER20	80	1	992.081.ER20
	Kinetic Dust Extractor for chucks with ER25	80	1	992.081.ER25
	Kinetic Dust Extractor for chucks with DIN6388/EOC25 collets	100	1	992.101.EOC25
	Kinetic Dust Extractor for chucks with ER32 collets	100	1	992.101.ER32
	Kinetic Dust Extractor for chucks with ER40 collets	100	1	992.101.ER40

Spare parts 991.285.00 C-Spanner 80-90mm (ER20/ER25)
991.284.00 C-Spanner 95-100mm (EOC25/ER32/ER40)



EASY TO USE!

Install & remove as a clamping nut

- Health & Safety
- Tool Performance & Cut Quality
- Tool Life & Labor Costs
- Recommended for Nesting and Routing operations
- No wasted time during work process
- Replaces the standard clamping nut
- Suitable for any collet chucks with standard router bits
- Available for ER32 - ER40 - EOC25 (DIN6388) collets
- The thick ceramic coat gives to KDE an anti-corrosion, anti-friction and anti-static surface.
- Tool body in light alloy
- Better air quality
- Good performances even at low rpm: from 6,000 up to 20,000 rpm
- Material: chipboard, coated chipboard, MDF, Corian®, plasterboard, OSB, HPL.

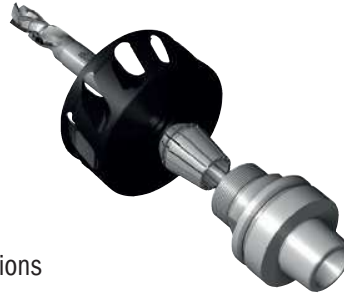

Always use vacuum system.

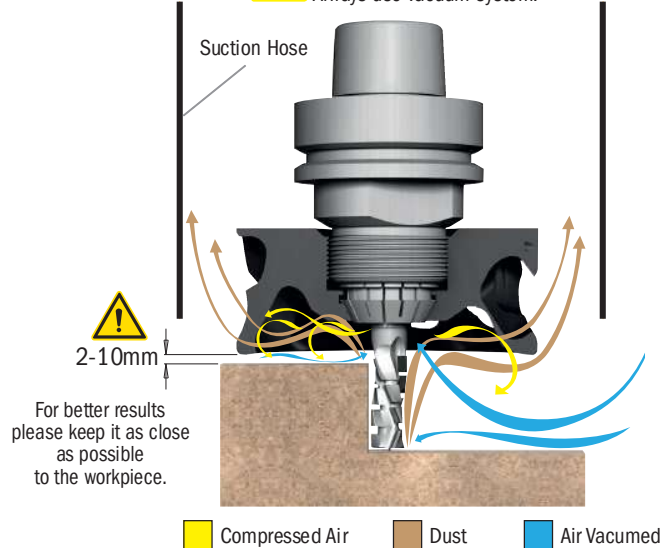

Download Instruction

Watch the video on



Watch Video

Working **WITHOUT** Kinetic Dust Extractor



Working **WITH** Kinetic Dust Extractor



HSK Chucks for "ER40" Precision Collets

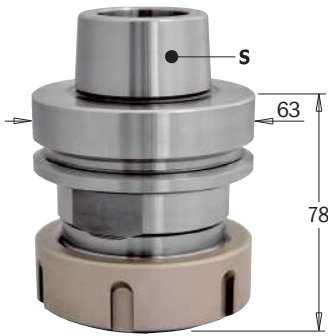

183.310 X-TREME



S	DESCRIPTION	TO BE USED WITH COLLET	BOX	ORDER NO. Left-hand rotation	ORDER NO. Left-hand rotation
HSK-63F	Clamping nut without bearing	ER40	1	183.310.01	183.310.02
HSK-63F	Clamping nut with bearing	ER40	1	183.310.11*	

Spare parts 990.117.00 M6x6mm screw

* Suitable for right-hand and left-hand rotation.



Non-Stick ORANGE CHROME® SHIELD COATING

- prevents overheating
- protects against corrosion and rust
- reduces resin build-up
- longer life and greater tool performance

For Homag, Eima, IMA from 9/94, Dubus, Weeke, Biesse, SCM, Morbidelli and Masterwood machines.

S	DESCRIPTION	TO BE USED WITH COLLET	BOX	ORDER NO. Right-hand rotation
new HSK-63F	Clamping nut without bearing	ER40	1	183.310.91

Spare parts 990.117.00 M6x6mm screw

Without Orange Chrome® Shield Coating

ISO30 Chucks for "ER40" Precision Collets



995.200

183.201



S	TO BE USED WITH COLLET	RETAINING STUD mm	BOX	ORDER NO. Right-hand rotation
ISO30	ER40	Ø12-8	1	183.201.01

For Biesse machines



995.201

183.211



S	TO BE USED WITH COLLET	RETAINING STUD mm	BOX	ORDER NO. Right-hand rotation
ISO30	ER40	Ø13-9	1	183.211.01

For Biesse machines with Omlat engine, Bulleri, Busellato, CMS and IMA machines.



995.202

183.221



S	TO BE USED WITH COLLET	RETAINING STUD mm	BOX	ORDER NO. Right-hand rotation
ISO30	ER40	Ø12,8-9	1	183.221.01

For Alberti and Masterwood machines.

Clamping Nuts for Chucks with "ER40" Precision Collets



992.383



DESCRIPTION	BOX	ORDER NO. Right-hand rotation	ORDER NO. Left-hand rotation
Clamping nut without bearing For 183.201/211/221/310 chucks	1	992.383.01	992.383.02
Clamping nut with bearing For 183.201/211/221/310 chucks	1	992.383.11	

TOOLBOX

Darbagaldi & Instrumenti

www.TOOLBOX.lv

info@toolbox.lv

C-spanner for "ER40" Precision Collets



991.184

DESCRIPTION	BOX	ORDER NO.
C-Spanner for "ER40" precision collet	1	991.184.00

HSK Chuck for "ER32" Precision Collets

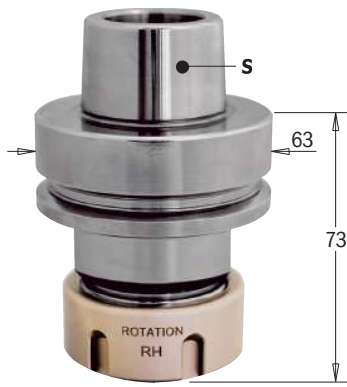

183.300 **EXTREME**



S	DESCRIPTION	TO BE USED WITH COLLET		ORDER NO. Right-hand rotation	ORDER NO. Left-hand rotation
HSK-63F	Clamping nut without bearing	ER32	1	183.300.01	183.300.02
HSK-63F	Clamping nut with bearing	ER32	1	183.300.11*	

Spare parts 990.118.00 M6x10mm screw

* Suitable for right-hand and left-hand rotation.



NON-STICK ORANGE CHROME® SHIELD COATING

- prevents overheating
- protects against corrosion and rust
- reduces resin build-up
- longer life and greater tool performance

For Homag, Eima from 9/94, Dubus, Weeke, Biesse, SCM, Morbidelli and Masterwood machines.

S	DESCRIPTION	TO BE USED WITH COLLET		ORDER NO. Right-hand rotation	ORDER NO. Left-hand rotation
new HSK-63F	Clamping nut without bearing	ER32	1	183.300.91	

Spare parts 990.118.00 M6x10mm screw

Without Orange Chrome® Shield Coating

ISO30 Chucks for "ER32" Precision Collets



183.200



S	TO BE USED WITH COLLET	RETAINING STUD mm		ORDER NO. Right-hand rotation	ORDER NO. Left-hand rotation
ISO30	ER32	Ø12-8	1	183.200.01	183.200.02

For Biesse machines.

183.210



S	TO BE USED WITH COLLET	RETAINING STUD mm		ORDER NO. Right-hand rotation	ORDER NO. Left-hand rotation
ISO30	ER32	Ø13-9	1	183.210.01	183.210.02

For Biesse machines with Omlat engine, Bulleri, Busellato, CMS and IMA machines.

183.220



S	TO BE USED WITH COLLET	RETAINING STUD mm		ORDER NO. Right-hand rotation	ORDER NO. Left-hand rotation
ISO30	ER32	Ø12,8-9	1	183.220.01	183.220.02

For Alberti and Masterwood machines.

ISO30 Chucks for "ER32" Precision Collets



183.250 without aluminium flange



S	TO BE USED WITH COLLET	RETAINING STUD mm		ORDER NO. Right-hand rotation	ORDER NO. Left-hand rotation
ISO30	ER32	Ø8,5	1	183.250.01	183.250.02

For Morbidelli and SCM machines.

183.251 with Ø69,5mm aluminium flange fully assembled (*)



S	TO BE USED WITH COLLET	RETAINING STUD mm		ORDER NO. Right-hand rotation	ORDER NO. Left-hand rotation
ISO30	ER32	Ø8,5	1	183.251.01	183.251.02

Spare parts 992.501.00 Ø69,5mm aluminium flange*

For Morbidelli and SCM machines.

Chucks for "ER32" Precision Collets



183.000/100

RH LH

S mm	TO BE USED WITH COLLET	H mm		ORDER NO. Right-hand rotation	ORDER NO. Left-hand rotation
MK2/M30x1,5	ER32	62	1	183.000.01	183.000.02
MK3/M30x1,5	ER32	70	1	183.100.01	

MK2/MK3 tapered shank



Chucks for "ER32" Precision Collets

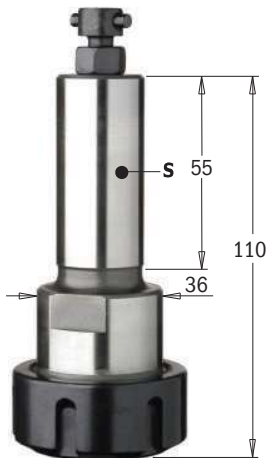

183.400

RH

S mm	TO BE USED WITH COLLET	RETAINING STUD		ORDER NO. Right-hand rotation
Ø25x55	ER32	PS LEUCO	1	183.400.01

995.400

For machines with PS Leuco system.

Clamping Nuts for Chucks with "ER32" Collets



992.183

RH LH

DESCRIPTION		ORDER NO. Right-hand rotation	ORDER NO. Left-hand rotation
Clamping nut without bearing For 183.000/100/200/250/300/400 chucks	1	992.183.01	992.183.02
Clamping nut with bearing For 183.000/100/200/250/300/400 chucks	1	992.183.11	992.183.12

C-Spanner for "ER32" Precision Collets



991.183

DESCRIPTION		ORDER NO.
C-Spanner for "ER32" precision collets	1	991.183.00

HSK Chuck for "DIN6388" - EOC25 Precision Collet

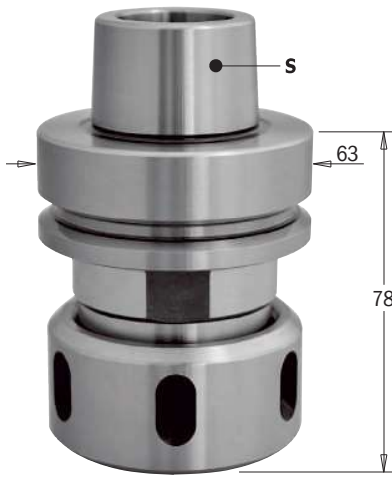

183.320

RH

S	DESCRIPTION	TO BE USED WITH COLLET		ORDER NO. Right-hand rotation
HSK-63F	HSK chuck with bearing nut	EOC-25	1	183.320.01*
new HSK-63F	HSK chuck without bearing nut	EOC-25	1	183.320.03

Spare parts 992.283.11 Clamping nut with bearing
992.283.01 Clamping nut without bearing

* Suitable for left-hand rotation too.

For Homag, Eima from 9/94, Dubus, Weeke, Biesse, SCM, Morbidelli & Masterwood machines.

Clamping Nuts



992.283

RH

DESCRIPTION		ORDER NO. Right-hand rotation
Clamping nut without bearing	1	992.283.01
Clamping nut with bearing	1	992.283.11

For chuck 183.320.

C-Spanner for "DIN6388" & "ER40"



991.283

DESCRIPTION		ORDER NO.
C-Spanner for 58-62-65	1	991.283.00

Precision Collets "DIN6388"



185 - EOC-25

mm	B inches		ORDER NO.	mm	B inches		ORDER NO.
3		10	185.030.00	12		10	185.120.00
4		10	185.040.00	12,7	1/2	10	185.127.00
5		10	185.050.00	14		10	185.140.00
6		10	185.060.00	16	5/8	10	185.160.00
6,35	1/4	10	185.064.00	18		10	185.180.00
8	5/16	10	185.080.00	19,05	3/4	10	185.191.00
9,5	3/8	10	185.095.00	20		10	185.200.00
10		10	185.100.00	25		10	185.250.00

REMARK: special dimensions available on request.



185 - EOC-16

mm	B inches		ORDER NO.	mm	B inches		ORDER NO.
6		10	185.060.16	12		10	185.120.16
8	5/16	10	185.080.16	14		10	185.140.16
10		10	185.100.16	16	5/8	10	185.160.16

REMARK: special dimensions available on request.

Precision Collets "DIN6499"



184 - ER11

B mm		ORDER NO.
2	10	184.020.11
3	10	184.030.11
4	10	184.040.11
5	10	184.050.11
6	10	184.060.11

TECHNICAL DETAILS:

- replaceable Std "ER11" collets (from 1 to 7mm)
- fit most tapered spindle noses
- +0-0,7mm wide clamping tolerance
- suitable for most conical chucks.

REMARK: special dimensions available on request.



184 - ER16

B mm		ORDER NO.
2	10	184.020.16
3	10	184.030.16
4	10	184.040.16
5	10	184.050.16
6	10	184.060.16
7	10	184.070.16
8	10	184.080.16
9	10	184.090.16
10	10	184.100.16

TECHNICAL DETAILS:

- replaceable Std "ER16" collets (from 1 to 10mm)
- fit most tapered spindle noses
- +0-0,7mm wide clamping tolerance
- suitable for most conical chucks.

REMARK: special dimensions available on request.



184 - ER20

B mm		ORDER NO.
2	10	184.020.20
3	10	184.030.20
4	10	184.040.20
5	10	184.050.20
6	10	184.060.20
6,35	10	184.064.20
7	10	184.070.20
8	10	184.080.20
9	10	184.090.20
10	10	184.100.20
11	10	184.110.20
12	10	184.120.20
12,7	10	184.127.20

TECHNICAL DETAILS:

- replaceable Std "ER20" collets (from 1 to 13mm)
- fit most tapered spindle noses
- +0-0,7mm wide clamping tolerance
- suitable for most conical chucks.

REMARK: special dimensions available on request.



184 - ER25

B mm		ORDER NO.
3	10	184.030.25
4	10	184.040.25
5	10	184.050.25
6	10	184.060.25
6,35	10	184.064.25
8	10	184.080.25
9	10	184.090.25
10	10	184.100.25
12	10	184.120.25
12,7	10	184.127.25
14	10	184.140.25
16	10	184.160.25

TECHNICAL DETAILS:

- replaceable Std "ER25" collets (from 1 to 16mm)
- fit most tapered spindle noses
- +0-0,7mm wide clamping tolerance
- suitable for most conical chucks.

REMARK: special dimensions available on request.



184 - ER32

B mm		ORDER NO.
3	10	184.030.00
4	10	184.040.00
5	10	184.050.00
6	10	184.060.00
6,35	10	184.065.00
7	10	184.070.00
8	10	184.080.00
9	10	184.090.00
9,52	10	184.095.00
10	10	184.100.00
11	10	184.110.00
12	10	184.120.00
12,7	10	184.127.00
14	10	184.140.00
15	10	184.150.00
16	10	184.160.00
17	10	184.170.00
18	10	184.180.00
19	10	184.190.00
20	10	184.200.00

For chucks
183.000/100/200/250/300/400

TECHNICAL DETAILS:

- replaceable Std "ER32" collets (from 3 to 20mm)
- fit most tapered spindle noses
- +0-0,7mm wide clamping tolerance
- suitable for most conical chucks.

REMARK: special dimensions available on request.



184 - ER40

B mm		ORDER NO.
3	10	184.032.00
4	10	184.042.00
5	10	184.052.00
6	10	184.062.00
6,35	10	184.064.00
7	10	184.072.00
8	10	184.082.00
9,52	10	184.096.00
10	10	184.102.00
12	10	184.122.00
12,7	10	184.128.00
14	10	184.142.00
16	10	184.162.00
18	10	184.182.00
19	10	184.192.00
20	10	184.202.00
25	10	184.252.00

For chucks
183.201/211/221/310

TECHNICAL DETAILS:

- replaceable Std "ER40" collets (from 3 to 25mm)
- fit most tapered spindle noses
- +0-0,7mm wide clamping tolerance
- suitable for most conical chucks.

REMARK: special dimensions available on request.

TOOLBOX
Darbagaldi & Instrumenti
www.TOOLBOX.lv info@toolbox.lv

Cap Nuts for CNC Machines



993.0

RH LH

INTERNAL THREAD			ORDER NO. Right-hand rotation	ORDER NO. Left-hand rotation
Ø20x14Fx1"		1	993.020.01	993.020.02
M30x1,5		1		993.030.02

For machines with M33x3 threaded spindle nose.

ISO30 Retaining Studs



DESCRIPTION	D ₁ mm	D ₂ mm	ORDER NO.
Retaining stud for 183.200/201 "Biesse" chucks	8	12	995.200.00
Retaining stud for 183.210/211 "Biesse, Omlat, Bulleri, Busellato, Weeke and IMA" chucks	9	13	995.201.00
Retaining stud for 183.220/221 "Alberti-Masterwood" chucks	9	12,8	995.202.00
Retaining stud for 183.250/251 "SCM - Morbidelli" chucks	6,5	8,5	995.250.00
Retaining stud for "PS and Leuco" 183.400 chucks	M8		995.400.00

Collet Chucks Clamp with MK2 Tapered Shank

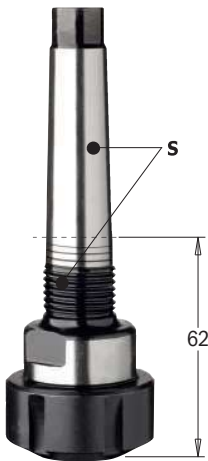

123

RH LH

S			ORDER NO. Right-hand rotation	ORDER NO. Left-hand rotation
MK2/Ø20x14Fx1"		1	123.000.01	123.000.02

Spare parts

992.123.01	Clamping nut RH
992.123.02	Clamping nut LH
991.123.00	Type 45-50 c-spanner

Collets for 123 Chucks



124

D ₃ mm		ORDER NO.	D ₃ mm		ORDER NO.
6	1	124.060.00	10	1	124.100.00
6,35	1	124.064.00	12	1	124.120.00
8	1	124.080.00	12,7	1	124.127.00
9,5	1	124.095.00	14	1	124.140.00

Saw Blade Arbor with Parallel Shank

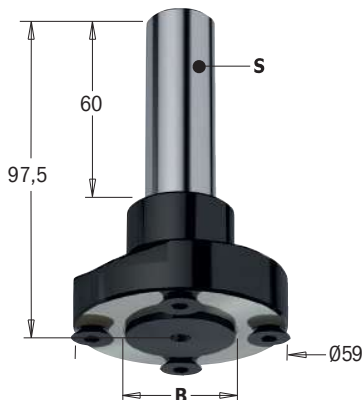

183.410

LH RH

S mm	D mm	B mm	PIN HOLE 	L mm		ORDER NO.
20	59	30	4/M6/48	97,5	1	183.410.30

Spare parts

990.116.00	M6x8,7x12mm TSPEI screw (to use with Plate Thickness ≥ 2,2mm)
991.067.00	3mm allen key
991.064.00	4mm allen key



Optional

990.083.00	M6x8x10mm TSPEI screw (to use with Plate Thickness < 2,2mm)
------------	---

HSK Chuck for Grooving Blade

new

CMT ORANGE TOOLS



183.420

LH RH

S	D mm	B mm	PIN HOLE	L mm		ORDER NO.
HSK-63F	59	30	4/M6/48	78	1	183.420.30

Spare parts 990.116.00 M6x8, 7x12mm TSPEI screw
991.064.00 4mm allen key



Max saw blade \varnothing 250mm for chuck 183.420.30



Grooving saw blades available at page 38 or on request.

HSK Chuck for Grooving Blade

new



183.421

LH RH

S	D mm	B mm	PIN HOLE	L mm		ORDER NO.
HSK-63F	98	30	6/M6/80	102	1	183.421.30

with flange \varnothing 98mm

Spare parts 990.116.00 M6x8, 7x12mm TSPEI screw
991.064.00 4mm allen key



Max saw blade \varnothing 300mm for chuck 183.421.30



Grooving saw blades available on request.

HSK Chuck for Grooving Blade

new



183.422

LH RH

S	D mm	B mm	PIN HOLE	L mm		ORDER NO.
HSK-63F	110	30	6/M6/80	40	1	183.422.30

Spare parts 990.116.00 M6x8, 7x12mm TSPEI screw
991.064.00 4mm allen key



Max saw blade \varnothing 350mm for chuck 183.422.30

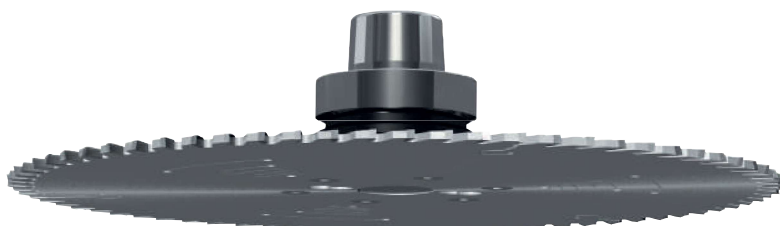

Grooving saw blades available on request.

Cutter Arbor with HSK Tapered Shank

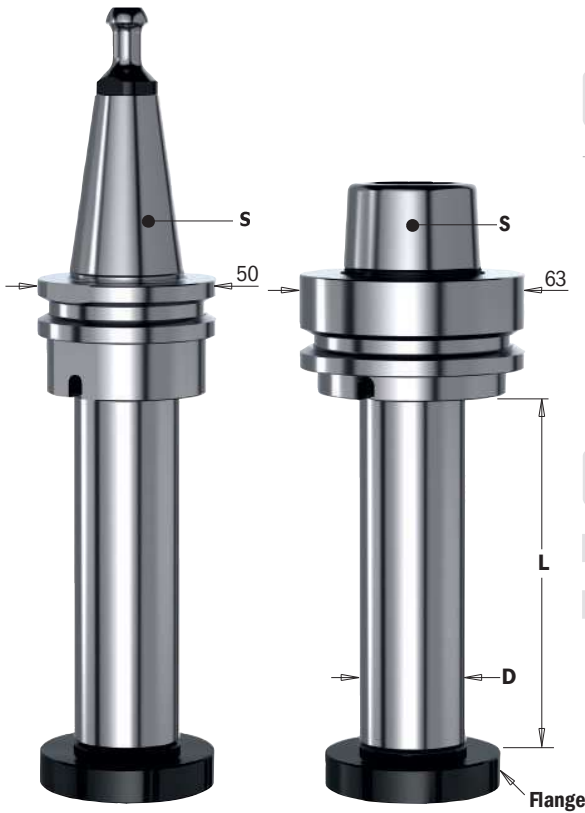

183.260

LH RH

S	DESCRIPTION	D x L mm		ORDER NO.
ISO30	Cutter arbor with ISO30 tapered shank	30x100	1	183.260.00

For Biesse machines.

REMARK: special dimensions available on request.

183.360

LH RH

S	DESCRIPTION	D x L mm		ORDER NO.
HSK-63F	Cutter arbor with HSK tapered shank	30x100	1	183.360.00
HSK-63F	Cutter arbor with HSK tapered shank	30x150	1	183.360.10
HSK-63F	Cutter arbor with HSK tapered shank	35x100	1	183.361.00
HSK-63F	Cutter arbor with HSK tapered shank	40x100	1	183.362.00

For Homag, Eima from 9/94, Dubus, Weeke, Biesse, SCM, Morbidelli and Masterwood machine.

Spare Parts for Chucks



DESCRIPTION	ORDER NO.	DESCRIPTION	ORDER NO.
M6x25 TCEI screw	990.098.00	<i>Optional</i>	
Steel flange for with Ø30mm arbors - Male	992.560.30M	Steel flange for with Ø30mm arbors - Female	992.560.30F
Steel flange for with Ø35mm arbors - Male	992.560.35M	Steel flange for with Ø35mm arbors - Female	992.560.35F
Steel flange for with Ø40mm arbors - Male	992.560.40M	Steel flange for with Ø40mm arbors - Female	992.560.40F

Universal Assembly Supports for Chucks



183

DESCRIPTION	D mm		ORDER NO.
Universal assembly supports for chucks HSK-63F	63	1	183-HSK
Universal assembly supports for chucks ISO30	50	1	183-ISO

For HSK-63F, BT40, ISO40 DIN 2080, SK40 DIN 69871, CAPTO C6 and ISO30, DIN 2080, SK30 DIN 69871, HSK50, CAPTO C5 chucks

CMT now offers new universal assembly supports for HSK-63F and ISO30 chucks. Thanks to the bi-directional roller bearings, which clamp the Left-hand rotation to the flange, the system offers the highest protection to the tool taper and clamps are no longer needed.

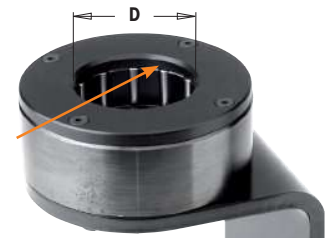



X-TREME COATING

THE ULTIMATE TECHNOLOGY FOR INDUSTRIAL CNC TOOLS

DLCS is a modified diamond-like carbon coating with enhanced load bearing capacity. A hard, durable metal-based layer (chromium nitride) provides an higher hardness surface and increases the resilience of the superposed, tribologically effective carbon coating. Coating prevents high heats which is detrimental to cutting tool performance and will remain fully effective after use.

Extreme Coating Hardness >HV 2.500

Offers impressive hardness on cutting areas of the tool and superb protection against abrasive wear and stress resistance.

Minimal coating thickness µm 2-4

The minimal micron coating guaranteed perfect sharpen edges for high cutting quality.

The lowest coefficient of friction 0,1-0,2

Very good running-in and low friction losses. Reduction of sticking. Ideal for high speeds in Nesting applications.

High Working Temperature

Less overheating! The coating guarantees working temperature up to 400° preserving the cutting edges from wear.

BENEFITS



3X
LONGER LIFE
THAN UNCOATED

DLCS CHROME COATING
provides 3 times longer life
than uncoated tools!



Test performed in U.S. with 1/2" solid carbide compression spiral bit

- MACHINE:** Felder Profit H10 Nested Base/Overhead CNC Router
- WORKING PARAMETERS:** RPM = 18,000 - Feed = 20 mts/minute
- MATERIAL:** 19mm Melamine Chipboard
- APPLICATION:** Nesting Full Dimensioning
- PERFORMANCE:** DLCS coated bit cut 165 melamine panels
Uncoated bit cut 56 melamine panels

Felder Profit H10



DLCS coated bit



Melamine Chipboard



Cut quality after 165 panels



Solid Carbide Upcut & Downcut Spiral Bits

new

CMT ORANGE TOOLS



EXTRA HARD
DLCS CHROME COATING

3X
LONGER LIFE
THAN UNCOATED

190.41 DLCS Chrome Coating Long Life

HWM Z2+2 Z3+3 RH LONG LIFE

D mm	I mm	I ₁ mm	L mm	S mm	Z		ORDER NO. Right-hand rotation
9,52	28,6	7	76,2	9,52	2+2	10	190.504.41
12	42	7	90	12	2+2	10	190.120.41
12	52	7	100	12	2+2	10	190.121.41
12,7	25,4	12	76,2	12,7	2+2	10	190.505.41
12,7	28,6	12	76,2	12,7	2+2	10	190.506.41
12,7	34,9	12	88,9	12,7	2+2	10	190.507.41
12,7	41,3	12	101,6	12,7	2+2	10	190.508.41

...up & downcut mortising bits

9,52	22,2	4,8	76,2	9,52	2+2	10	190.513.41
9,52	25,4	5,2	76,2	9,52	3+3	10	190.813.41
12	25	5,2	83	12	3+3	10	190.320.41
12,7	22,2	5,2	76,2	12,7	2+2	10	190.515.41
12,7	34,9	5,2	88,9	12,7	2+2	10	190.517.41
12,7	28,5	6	76,2	12,7	3+3	10	190.815.41

TECHNICAL DETAILS:

- Premium quality HWM.
- 2+2 spiral cutting edges [Z2+2].
- 3+3 spiral cutting edges [Z3+3].
- Provide an excellent finish on both the upper and the lower side of the workpiece.

APPLICATION:

used for cutting, copying, panel sizing and any routing application on solid wood, wood composites, plastic materials and laminates. Use a high feed speed on well-clamped workpieces. Can be used on machining centres, point-to-point boring machines, CNC routers and hand-held routers equipped with chucks or adapters.

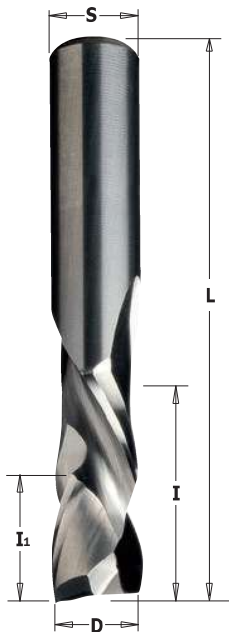

190

HWM Z1+1 Z2+2 Z3+3 RH

D mm	I mm	I ₁ mm	L mm	S mm	Z		ORDER NO. Right-hand rotation
4	15	7	50	4	1+1	10	190.040.11
5	22	8	60	5	1+1	10	190.050.11
6	22	8	60	6	1+1	10	190.060.11
6,35	22,2	7	63,5	6,35	2+2	10	190.008.11
8	32	7	80	8	2+2	10	190.080.11
9,52	28,6	7	76,2	9,52	2+2	10	190.504.11
10	32	7	80	10	2+2	10	190.100.11
10	42	7	90	10	2+2	10	190.101.11
12	42	7	90	12	2+2	10	190.120.11
12	52	7	100	12	2+2	10	190.121.11
12,7	25,4	12	76,2	12,7	2+2	10	190.505.11
12,7	28,6	12	76,2	12,7	2+2	10	190.506.11
12,7	34,9	12	88,9	12,7	2+2	10	190.507.11
12,7	41,3	12	101,6	12,7	2+2	10	190.508.11
16	55	24	110	16	2+2	10	190.160.11
18	55	30	110	18	2+2	10	190.180.11

...up & downcut mortising bits

9,52	22,2	4,8	76,2	9,52	2+2	10	190.513.11
9,52	25,4	5,2	76,2	9,52	3+3	10	190.813.11
12	25	5,2	83	12	3+3	10	190.320.11
12,7	22,2	5,2	76,2	12,7	2+2	10	190.515.11
12,7	34,9	5,2	88,9	12,7	2+2	10	190.517.11
12,7	28,5	6	76,2	12,7	3+3	10	190.815.11

TECHNICAL DETAILS:

- Premium quality HWM.
- 1+1 spiral cutting edges [Z1+1].
- 2+2 spiral cutting edges [Z2+2].
- 3+3 spiral cutting edges [Z3+3].
- Provide an excellent finish on both the upper and the lower side of the workpiece.

APPLICATION:

used for cutting, copying, panel sizing and any routing application on solid wood, wood composites, plastic materials and laminates. Use a high feed speed on well-clamped workpieces. Can be used on machining centres, point-to-point boring machines, CNC routers and hand-held routers equipped with chucks or adapters.



Results shown in this diagram are purely empirical, based merely on informative and hypothetical calculation. Each application may require different parameters in consideration of materials in use and machining conditions. CMT is not responsible for direct, indirect, incidental or consequential damages resulting from any defect, error or failure due to this diagram.

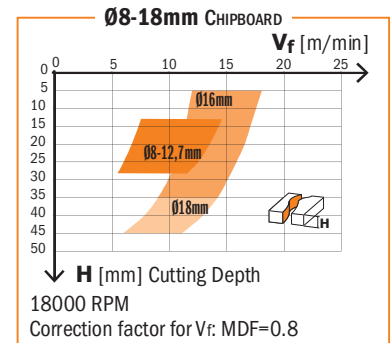
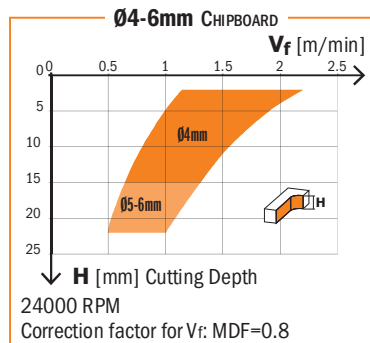

Solid Carbide Upcut Spiral Bits

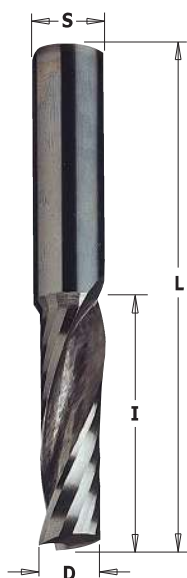

198



D mm	I mm	L mm	S mm		ORDER NO. Right-hand rotation
3	12	50	3	10	198.030.11
3,18	12,7	50,8	6,35	10	198.001.11
4	15	50	4	10	198.040.11
4,76	15,87	50,8	6,35	10	198.005.11
5	17	50	5	10	198.050.11
6	22	60	6	10	198.060.11
6,35	19,05	50,8	6,35	10	198.007.11
6,35	25,4	63,5	6,35	10	198.008.11
8	22	70	8	10	198.080.11
8	32	80	8	10	198.081.11
9,52	28,57	76,2	9,52	10	198.504.11
10	32	70	10	10	198.100.11
10	42	80	10	10	198.101.11
10	52	90	10	10	198.102.11
12	32	83	12	10	198.120.11

TECHNICAL DETAILS:

- Premium quality HWM.
- 1 spiral cutting edge [Z1].
- Provide an excellent finish on the lower side of the workpiece.
- **Upward chip ejection.**

APPLICATION:

used for cutting, copying, panel sizing and any routing applications on solid wood, wood composites, plastic materials and laminates. Use a high feed speed on well-clamped workpieces. Can be used on machining centres, point to point machines, CNC routers and hand-held routers equipped with chucks or adapters.

TOOLBOX
Darbagaldi & Instrumenti
www.TOOLBOX.lv info@toolbox.lv

Solid Carbide Downcut Spiral Bits



198



D mm	I mm	L mm	S mm		ORDER NO. Right-hand rotation
6	27	60	6	10	198.660.11

TECHNICAL DETAILS:

- Premium quality HWM.
- 1 spiral cutting edge [Z1].
- Provide an excellent finish on the top side of the workpiece.
- **Upward chip ejection.**

APPLICATION:

used for cutting, copying, panel sizing and any routing applications on solid wood, wood composites, plastic materials and laminates. Use a high feed speed on well-clamped workpieces. Can be used on machining centres, point to point machines, CNC routers and hand-held routers equipped with chucks or adapters.

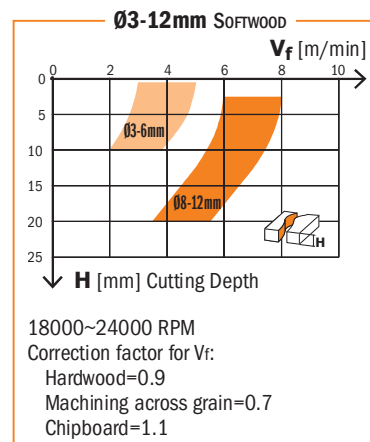
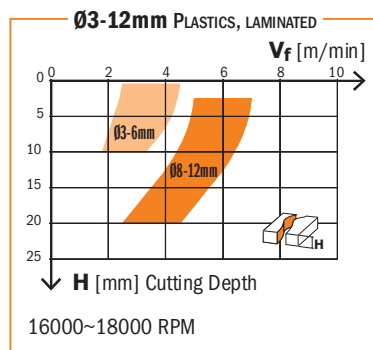

Results shown in this diagram are purely empirical, based merely on informative and hypothetical calculation. Each application may require different parameters in consideration of materials in use and machining conditions. CMT is not responsible for direct, indirect, incidental or consequential damages resulting from any defect, error or failure due to this diagram.

Solid Carbide Upcut Spiral Bits



191

D mm	I mm	L mm	S mm		ORDER NO. Right-hand rotation
3	12	50	3	10	191.030.11
3	12	60	6	10	191.630.11
3	12	60	8	10	191.830.11
3,18	12,7	50,8	6,35	10	191.001.11
3,5	12	60	6	10	191.635.11
3,97	12,7	50,8	6,35	10	191.003.11
4	15	50	4	10	191.040.11
4	15	60	6	10	191.640.11
4	15	60	8	10	191.840.11
4,76	19,05	50,8	6,35	10	191.005.11
5	17	50	5	10	191.050.11
5	17	60	6	10	191.650.11
5	17	60	8	10	191.850.11
6	27	70	6	10	191.060.11
6	27	70	8	10	191.860.11
6,35	19,05	50,8	6,35	10	191.007.11
6,35	25,4	63,5	6,35	10	191.008.11
7	32	80	8	10	191.870.11
7,94	25,4	76,2	12,7	10	191.501.11
8	22	70	8	10	191.080.11
8	32	80	8	10	191.081.11
8	42	90	8	10	191.082.11
9	32	83	12	10	191.890.11
9,52	31,75	82,5	12,7	10	191.503.11
10	32	80	8	10	191.800.11
10	32	80	10	10	191.100.11
10	32	83	12	10	191.900.11
10	42	90	10	10	191.101.11
10	42	90	12	10	191.901.11
12	35	83	8	10	191.820.11
12	35	83	12	10	191.120.11
12	42	90	12	10	191.121.11
12	52	100	12	10	191.122.11
12,7	31,75	76,2	12,7	10	191.505.11
12,7	38,1	88,9	12,7	10	191.506.11
12,7	50,8	101,6	12,7	10	191.507.11
14	50	110	14	1	191.140.11
16	55	110	16	1	191.160.11
16	35	90	16	1	191.161.11
16	72	120	16	1	191.165.11
20	72	120	20	1	191.200.11

Ø12-14mm PLASTICS, LAMINATED

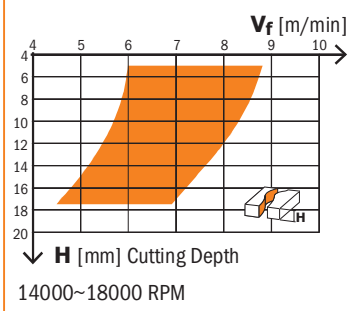

Ø12-20mm SOFTWOOD

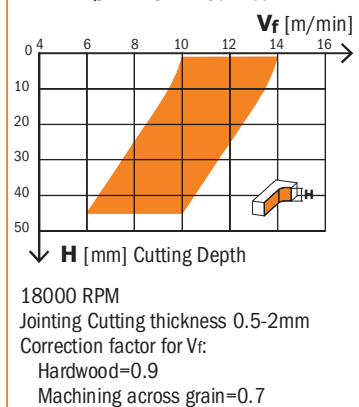

TECHNICAL DETAILS:

- Premium quality HWM.
- 2 spiral cutting edges [Z2].
- Provide an excellent finish on the lower side of the workpiece.
- **Upward chip ejection.**

APPLICATION:

used for ripping, template routing, panel sizing and any routing application on solid wood, wood composites, plastic materials and laminates. Can be used at a high feed speed on well-clamped workpieces. Can be used on machining centres, point-to-point boring machines, CNC routers and hand-held routers equipped with chucks or adapters.

TOOLBOX

Darbagaldi & Instrumenti

www.TOOLBOX.lv

info@toolbox.lv

Results shown in this diagram are purely empirical, based merely on informative and hypothetical calculation. Each application may require different parameters in consideration of materials in use and machining conditions. CMT is not responsible for direct, indirect, incidental or consequential damages resulting from any defect, error or failure due to this diagram.



192

D mm	I mm	L mm	S mm		ORDER NO. Right-hand rotation
3	12	50	3	10	192.030.11
3	12	60	6	10	192.630.11
3	12	60	8	10	192.830.11
3,18	12,7	50,8	6,35	10	192.001.11
3,97	12,7	50,8	6,35	10	192.003.11
4	15	50	4	10	192.040.11
4	15	60	6	10	192.640.11
4	15	60	8	10	192.840.11
4,76	19,05	50,8	6,35	10	192.005.11
5	17	50	5	10	192.050.11
5	17	60	6	10	192.650.11
5	17	60	8	10	192.850.11
6	27	70	6	10	192.060.11
6	27	70	8	10	192.860.11
6,35	19,05	50,8	6,35	10	192.007.11
6,35	25,4	63,5	6,35	10	192.008.11
7,94	25,4	76,2	12,7	10	192.501.11
8	22	70	8	10	192.080.11
8	32	80	8	10	192.081.11
8	42	90	8	10	192.082.11
9,52	31,75	82,5	12,7	10	192.503.11
10	32	80	8	10	192.800.11
10	32	80	10	10	192.100.11
10	42	90	10	10	192.101.11
10	32	83	12	10	192.900.11
12	35	83	8	10	192.820.11
12	35	83	12	10	192.120.11
12,7	31,75	76,2	12,7	10	192.505.11
12,7	38,1	88,9	12,7	10	192.506.11
12,7	50,8	101,6	12,7	10	192.507.11
14	52	110	14	1	192.140.11
16	55	110	16	1	192.160.11

Ø12-14mm PLASTICS, LAMINATED

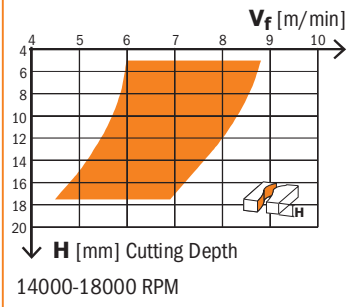

Ø12-20mm SOFTWOOD

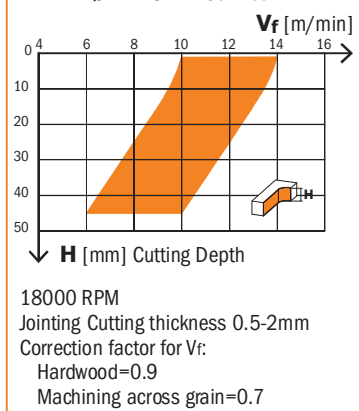

TECHNICAL DETAILS:

- Premium quality HWM.
- 2 spiral edges [Z2].
- Provide an excellent finish on the upper side of the workpiece.
- **Downward chip ejection.**

APPLICATION:

used for ripping, template routing, panel sizing and any routing application on solid wood, wood composites, plastic materials and laminates. Can be used at a high feed speed on small, difficult to clamp work pieces. Can be used on machining centres, point-to-point boring machines, CNC routers and hand-held routers equipped with chucks or adapters.



Results shown in this diagram are purely empirical, based merely on informative and hypothetical calculation. Each application may require different parameters in consideration of materials in use and machining conditions. CMT is not responsible for direct, indirect, incidental or consequential damages resulting from any defect, error or failure due to this diagram.

Solid Carbide Upcut Spiral Bits

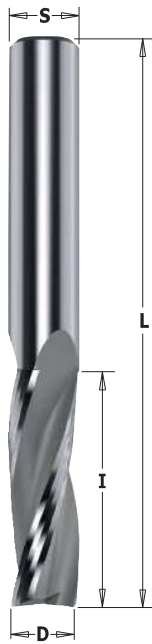

193

D mm	I mm	L mm	S mm		ORDER NO. Right-hand rotation	ORDER NO. Left-hand rotation
8	32	80	8	10	193.081.11	193.081.12
10	32	80	10	10	193.100.11	193.100.12
10	42	90	10	10	193.101.11	
12	35	83	12	10	193.120.11	193.120.12
12	42	90	12	10	193.121.11	
12	52	100	12	10	193.122.11	
14	58	110	14	1	193.140.11	
16	55	110	16	1	193.160.11	193.160.12
16	35	90	16	1	193.161.11	
16	72	120	16	1	193.165.11	
18	55	110	18	1	193.180.11	
20	60	120	20	1	193.200.11	193.200.12
20	70	120	20	1	193.201.11	

TECHNICAL DETAILS:

- Premium quality HWM.
- 3 spiral cutting edges [Z3].
- Provide an excellent finish on the lower side of the workpiece.
- **Upward chip ejection.**

APPLICATION:

used for ripping, template routing, panel sizing and any routing application on solid wood, or wood composites. Can be used at a high feed speed on well-clamped workpieces. Can be used on machining centres, point-to-point boring machines, CNC routers and hand-held routers equipped with chucks or adapters.

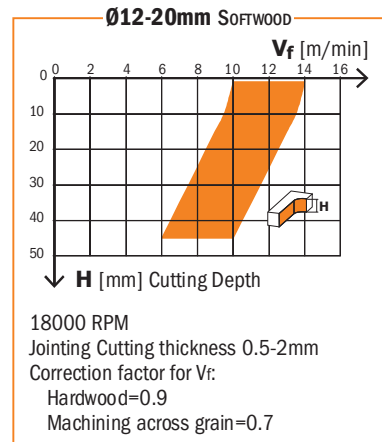
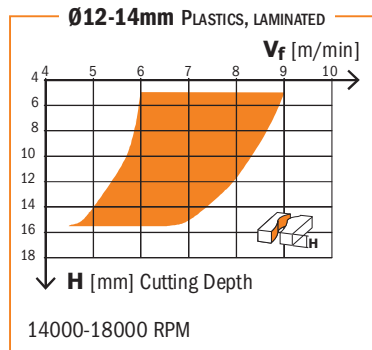

Results shown in this diagram are purely empirical, based merely on informative and hypothetical calculation. Each application may require different parameters in consideration of materials in use and machining conditions. CMT is not responsible for direct, indirect, incidental or consequential damages resulting from any defect, error or failure due to this diagram.

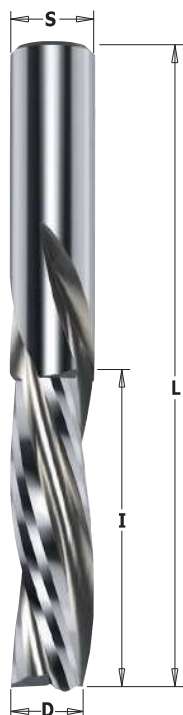

194



D mm	I mm	L mm	S mm		ORDER NO. Right-hand rotation	ORDER NO. Left-hand rotation
10	32	80	10	10	194.100.11	
10	42	90	10	10	194.101.11	
12	35	83	12	10	194.120.11	194.120.12
12	42	90	12	10	194.121.11	
14	50	110	14	1	194.140.11	
16	55	110	16	1	194.160.11	194.160.12
16	35	90	16	1	194.161.11	
18	55	110	18	1	194.180.11	
20	60	120	20	1	194.200.11	194.200.12
20	72	120	20	1	194.201.11	
20	102	165	20	1	194.202.11	

TECHNICAL DETAILS:

- Premium quality HWM.
- 3 spiral cutting edges [Z3].
- Provide an excellent finish on the upper side of the workpiece.
- **Downward chip ejection.**

APPLICATION:

used for ripping, template routing, panel sizing and any routing application on solid wood, wood composites, plastic materials and laminates. Can be used at a high feed speed on small, difficult to clamp workpieces.

Can be used on machining centres, point-to-point boring machines, CNC routers and hand-held routers equipped with chucks or adapters.

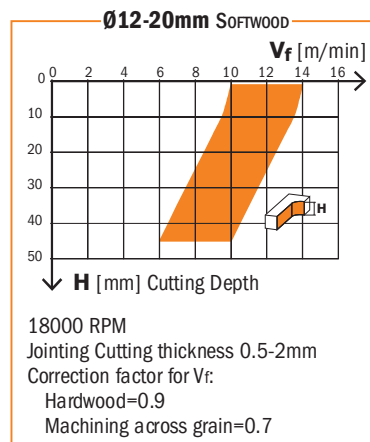
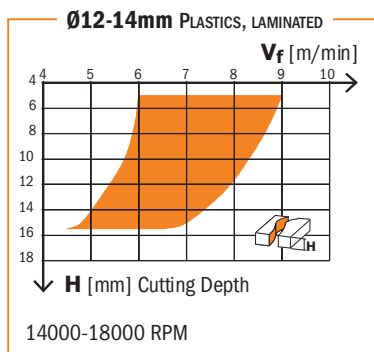

Results shown in this diagram are purely empirical, based merely on informative and hypothetical calculation. Each application may require different parameters in consideration of materials in use and machining conditions. CMT is not responsible for direct, indirect, incidental or consequential damages resulting from any defect, error or failure due to this diagram.

Solid Carbide Upcut Spiral Bits with Chip-Breaker



195

D mm	I mm	L mm	S mm		ORDER NO. Right-hand rotation	ORDER NO. Left-hand rotation
8	32	80	8	10	195.081.11	195.081.12
8	42	90	8	10	195.082.11	
10	32	80	10	10	195.100.11	195.100.12
10	42	90	10	10	195.101.11	
12	35	83	12	10	195.120.11	195.120.12
12	42	90	12	10	195.121.11	
12	52	100	12	10	195.122.11	
12,7	38,1	88,9	12,7	10	195.506.11	
14	58	110	14	1	195.140.11	
16	55	110	16	1	195.160.11	195.160.12
16	35	90	16	1	195.161.11	
16	72	120	16	1	195.165.11	
18	55	110	18	1	195.180.11	
20	60	120	20	1	195.200.11	195.200.12
20	72	120	20	1	195.201.11	
20	102	165	20	1	195.202.11	

APPLICATION:

used for ripping, template routing, panel sizing and any routing application on solid wood, or wood composites. Can be used at a high feed speed on well-clamped workpieces. Can be used on machining centres, point-to-point boring machines, CNC routers and hand-held routers equipped with chucks or adapters.

TECHNICAL DETAILS:

- Premium quality HWM.
- 3 spiral cutting edges [Z3R].
- Chip breaker teeth.
- Max 0.3mm tooth depth.
- Provide an excellent finish on the lower side of the workpiece.
- **Upward chip ejection.**



Results shown in this diagram are purely empirical, based merely on informative and hypothetical calculation. Each application may require different parameters in consideration of materials in use and machining conditions. CMT is not responsible for direct, indirect, incidental or consequential damages resulting from any defect, error or failure due to this diagram.

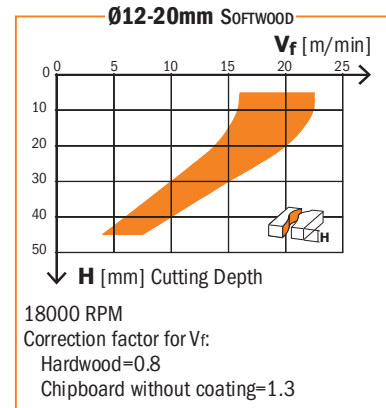
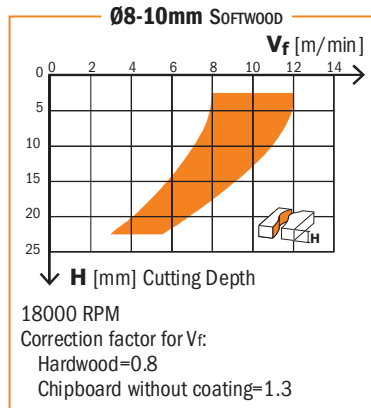

Solid Carbide Upcut Spiral Bits

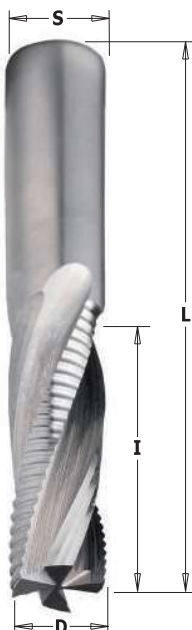

197



D mm	I mm	L mm	S mm		ORDER NO. Right-hand rotation
12	42	90	12	10	197.121.11
14	50	110	14	1	197.140.11
16	55	110	16	1	197.160.11
16	35	90	16	1	197.161.11
18	55	110	18	1	197.180.11
20	60	120	20	1	197.200.11
20	70	120	20	1	197.201.11

TECHNICAL DETAILS:

- Premium quality HWM.
- 4 spiral cutting edges (2 with chip-breaker) [Z2+2R].
- Max 0.1mm tooth depth.
- Provide excellent finish on the lower side of the workpiece.
- **Upward chip ejection.**



APPLICATION:

used for ripping, template routing, panel sizing and any routing application on solid wood and wood composites. Can be used on machining centres, point-to-point boring machines, CNC routers and hand-held routers equipped with chucks or adapters.

The special 4 flute design (Z2 finishing + Z2R with chipbreaker) allows high speed with excellent finish on the workpiece.

Solid Carbide Downcut Spiral Bits with Chip-Breaker

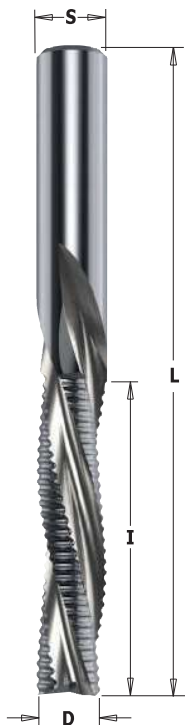

196



D mm	I mm	L mm	S mm		ORDER NO. Right-hand rotation	ORDER NO. Left-hand rotation
8	32	80	8	10	196.081.11	
10	42	90	10	10	196.101.11	
12	35	83	12	10	196.120.11	196.120.12
12	42	90	12	10	196.121.11	
12	52	100	12	10	196.122.11	
12,7	38,1	88,9	12,7	10	196.506.11	
14	50	110	14	1	196.140.11	
16	55	110	16	1	196.160.11	196.160.12
18	55	110	18	1	196.180.11	
20	60	120	20	1	196.200.11	196.200.12
20	72	120	20	1	196.201.11	

TECHNICAL DETAILS:

- Premium quality HWM.
- 3 spiral cutting edges [Z3R].
- Chip breaker teeth.
- Max 0.3mm tooth depth.
- Provide excellent finish on the upper side of the workpiece.
- **Downward chip ejection.**

APPLICATION:

used for ripping, template routing, panel sizing and any routing application on solid wood and wood composites.
Can be used on machining centres, point-to-point boring machines, CNC routers and hand-held routers equipped with chucks or adapters.

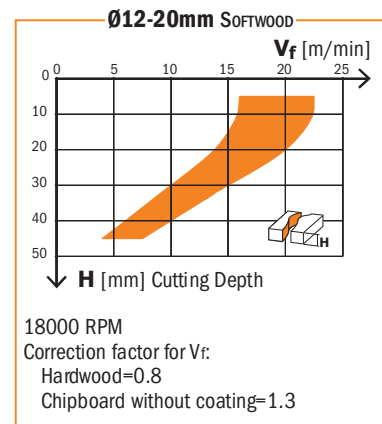
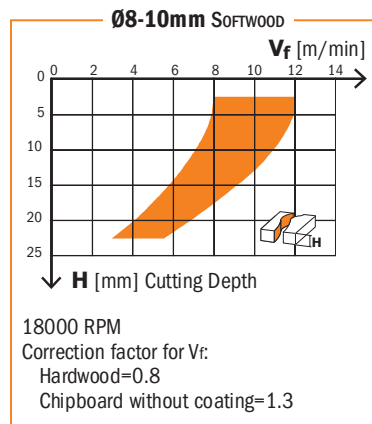

Results shown in this diagram are purely empirical, based merely on informative and hypothetical calculation. Each application may require different parameters in consideration of materials in use and machining conditions. CMT is not responsible for direct, indirect, incidental or consequential damages resulting from any defect, error or failure due to this diagram.

Solid Carbide Upcut Spiral Bits for Locksets

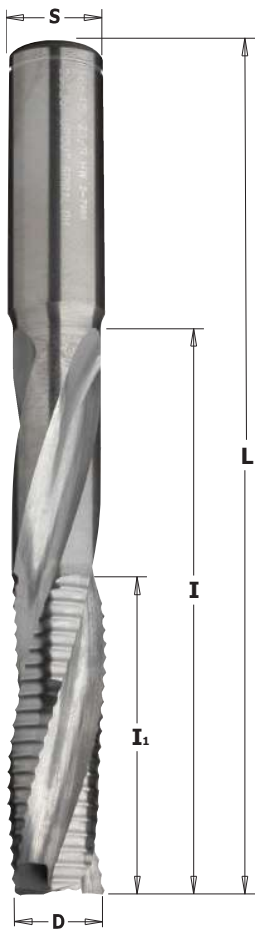

195



D mm	I mm	I ₁ mm	L mm	S mm		ORDER NO. Right-hand rotation
With Chip-Breaker						
14	95*	45	150	14	1	195.142.11
14	125*	45	170	14	1	195.144.11
16	95*	45	150	16	1	195.162.11
16	120*	50	170	16	1	195.164.11
18	95*	45	150	18	1	195.182.11
Without Chip-Breaker						
16	95*	45	150	16	1	193.162.11

* The maximum cutting length is achieved in 2-3 passes.

TECHNICAL DETAILS:

- Premium quality HWM.
- 3 spiral cutting edges [Z3] and [Z3R].
- Max 0.3mm tooth depth.
- Provide an excellent finish on the lower side of the workpiece.
- Seat for seeger ring (not included).
- **Upward chip ejection.**

APPLICATION:

used for ripping, template routing, panel sizing and any routing application on solid wood, or wood composites. Can be used at a high feed speed on well-clamped workpieces. Can be used on machining centres, point-to-point boring machines, CNC routers and hand-held routers equipped with chucks or adapters.

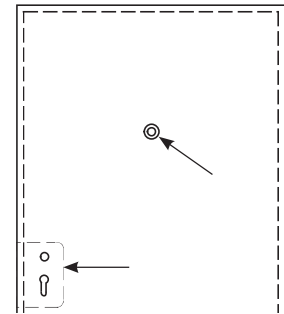
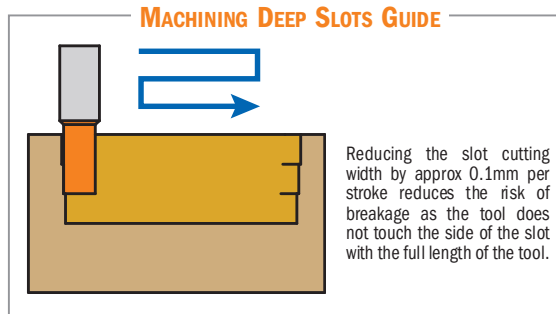

Solid Carbide Upcut with Spiral Bits Chip-Breaker for 60° V-Point Locksets

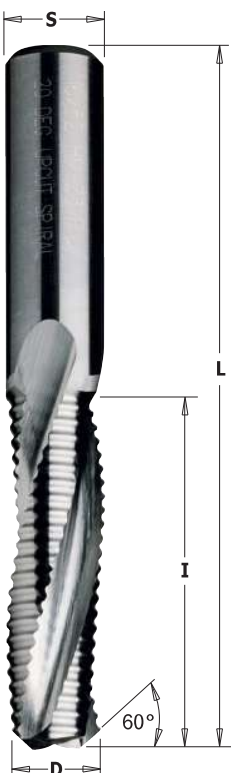

195.143/163



D mm	I mm	L mm	S mm		ORDER NO. Right-hand rotation
14	58	110	14	1	195.143.11
16	55	110	16	1	195.163.11

Solid Carbide Upcut Spiral Bits without Chip-Breaker for 60° V-Point Locksets

191.143/163



D mm	I mm	L mm	S mm	PACK QTY.	ORDER NO. Right-hand rotation
14	50	110	14	1	191.143.11
16	55	110	16	1	191.163.11

TECHNICAL DETAILS:

- Premium quality HWM.
- 3 spiral cutting edges [Z3].
- Provide an excellent finish on the lower side of the workpiece.
- **Upward chip ejection.**

APPLICATION:

used for ripping, template routing, panel sizing and any routing application on solid wood, or wood composites. Can be used at a high feed speed on well-clamped workpieces. Can be used on machining centres, point-to-point boring machines, CNC routers and hand-held routers equipped with chucks or adapters.

Spiral Bits with Insert Knives & Chip-Breaker for Locksets

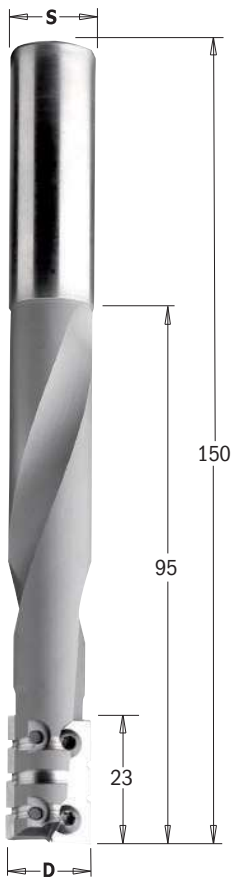

662



D mm	I mm	L mm	S mm	Box	ORDER NO. Right-hand rotation
16	23/95*	150	16	1	662.160.11

Spare parts

790.230.2R	23x7x1.5mm 2-RT HWM knives (Minimum 10 pieces or multiple)
790.230.2R-X2	23x7x1.5mm 2-RT HWM knives (2-piece pack)
790.230.3R	23x7x1.5mm 3-RT HWM knives (Minimum 10 pieces or multiple)
790.230.3R-X2	23x7x1.5mm 3-RT HWM knives (2-piece pack)
990.082.00	M3x4x5.7mm T8 Torx TCPTI screw
991.063.00	T8 Torx key

* The 95mm length is achieved in 4-5 passes.

TECHNICAL DETAILS:

- Densimet® tungsten heavy metal alloys for low-vibration.
- 2 cutting edges [Z2R].
- Chip-breaker teeth.

APPLICATION:

used for ripping, template routing, panel sizing and any routing application on solid wood, or wood composites. Can be used at a high feed speed on well-clamped workpieces. Can be used on machining centres, point-to-point boring machines, CNC routers and hand-held routers equipped with chucks or adapters.

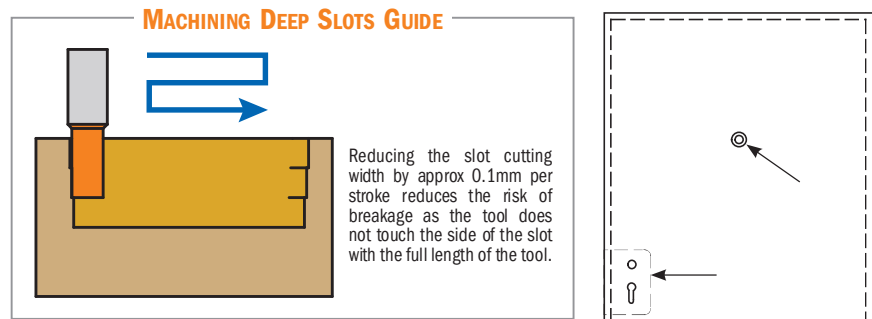

Upcut Spiral Bits with Chipbreaker for Glue-Laminated Wooden Beams

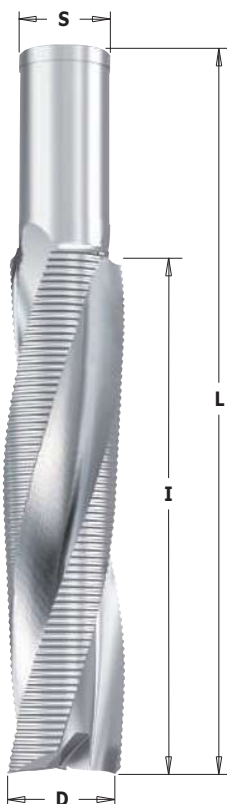

195



D mm	I mm	L mm	S mm	Box	ORDER NO. Right-hand rotation
□ 30	170	235	30	1	Y195.300.51
40	165	235	30	1	195.400.51
50	215	295	30	1	195.500.51

On request

We manufacture bits without chipbreaker, with left-hand rotation and also in custom dimensions.

TECHNICAL DETAILS:

- High speed cobalt steel.
- 3 upcut spiral cutting edges with chipbreaker [Z3R].
- Resharpener cutters.
- Max 6000~10000 RPM.
- Maximum feed speed 2m/minute.
- **Upward chip ejection.**

APPLICATION:

used for cutting, copying, and routing on glue-laminated wooden beams. For use on Hundegger machines.



Solid Carbide Upcut 2D/3D Carving Tapered Ball Nose Spiral Bits



152

D mm	R mm	A	I mm	L mm	S mm	Z		ORDER NO. Right-hand rotation
0,8	0,4	5,5°	25	70	6	3	10	152.060.082
0,8	0,4	6,2°	25,4	76,2	6,35	3	10	152.064.082
1,6	0,8	4,5°	25	70	6	3	10	152.060.162
1,6	0,8	5,4°	25,4	76,2	6,35	3	10	152.064.162
1,6	0,8	5,5°	30	80	8	3	10	152.080.163
2	1	3°	80	120	12	2	10	152.120.208
3,2	1,6	2,5°	30	70	6	3	10	152.060.323
3,2	1,6	3,6°	25,4	76,2	6,35	3	10	152.064.322
3,2	1,6	2,5°	50	90	8	3	10	152.080.325
6	3	3°	50	100	12	2	10	152.120.605
6,4	3,2	3°	50,8	101,6	12,7	2	10	152.127.635

TECHNICAL DETAILS:

- Premium quality HWM.
- Upcut spiral cutting edges [Z2/Z3].
- **Excellent finish on the lower side of the work piece.**
- Upward chip ejection.

APPLICATION: specially designed for 2D and 3D CNC profiling and carving in plastic, aluminum & wood for several uses like:

- A perfect bit for 3D carving
- Precision 2D and 3D large scale carving
- Great for deep profiling
- Dimensional signage
- 3D millwork
- 2D and 3D contouring, profiling, modeling and pattern making for cabinetry, sign making, furniture making and jewelry mold making
- Perfect for model-makers on large 3D milling profiles in abrasive EPS foam and other materials.
- **Ideal on aluminum, plastic and wood-based materials.**

EXCELLENT FOR CUTTING:

- Acrylonitrile-Butadiene-Styrene (ABS)
- Acrylic
- Acrylic Stone
- Aluminum
- Brass
- Bronze
- Composite
- Copper
- Corian®
- Coroplast®
- Dibond®
- Ethafoam®
- Ethylene-vinyl Acetate Foam (EVA)
- Expanded Polypropylene (EPP)
- Expanded Polystyrene Foam (EPS)
- Extruded Polystyrene Foam (XPS)
- Fiberglass
- Fiberglass PCB Board
- Foam Board
- Graphite
- HDPE
- HDU
- 20lbs High Density Urethane
- Lexan®
- MDF/HDF
- PALFOAM™
- Phenolics
- Phenolic Composites

- Plastics
- Poly (methyl methacrylate) (PMMA)
- Polyethylene Foam
- Polyam®
- Polyurethane Foam
- PVC
- PVC Foam Board
- Sign Board
- Sign Foam
- Titanium
- Tooling Board
- Wood
- XPE (Cross Linked Polyethylene) Foam

TIPS FOR MILLING PLASTICS

- pay attention to heat input
- pay attention to chip-loads when using small diameters
- use air-blast to keep chip away and cooling the tool

Round Nose Solid Carbide Upcut Spiral Bits

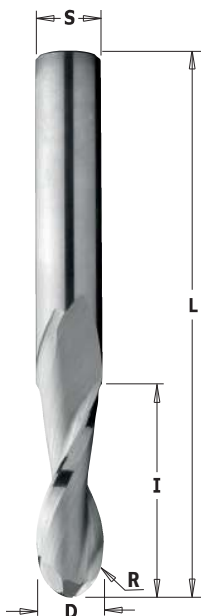

199

D mm	R mm	I mm	L mm	S mm		ORDER NO. Right-hand rotation
3,18	1,6	12,7	50,8	6,35	10	199.001.11
6	3	27	70	6	10	199.060.11
6,35	3,18	25,4	63,5	6,35	10	199.008.11
8	4	32	80	8	10	199.081.11
9,52	4,76	28,57	76,2	9,52	10	199.504.11
10	5	32	80	10	10	199.100.11
12	6	35	80	12	10	199.120.11
12,7	6,35	31,75	76,2	12,7	10	199.505.11
15,88	7,94	57,15	109,5	15,88	1	199.509.11
16	8	55	110	16	1	199.160.11
19,05	9,52	57,15	109,5	19,05	1	199.511.11

TECHNICAL DETAILS:

- Premium quality HWM.
- 2 upcut spiral cutting edges [Z2].
- Excellent finish on the lower side of the work piece.
- **Upward chip ejection.**

APPLICATION:

used for ripping, template routing, panel sizing and any routing application on solid wood, wood composites, plastic materials and laminates. Can be used at a high feed speed on well-clamped workpieces. For use on machining centers, point-to-point boring machines, CNC routers and hand-held routers equipped with chucks or adapters.

Solid Surface and Fiberglass Bit with DLCS Chrome Coating

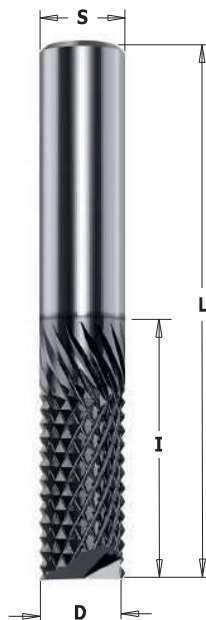

151 **XTRME**
PERFORMANCE



D mm	I mm	L mm	S mm		ORDER NO. Right-hand rotation
6	19	60	6	10	151.060.19E
6,35	25,4	63,5	6,35	10	151.064.25E
8	25	60	8	10	151.080.25E
12	25	75	12	10	151.120.25E
12,7	38	89	12,7	10	151.127.38E

TECHNICAL DETAILS:

- Premium quality HWM
- Special positively ground cutting edge sharpening for excellent finish
- AlTiN coated

APPLICATION:

for drilling, sizing and jointing fiberglass, phenolic and solid surfaces. Can be used on machining centres, point to point machines, CNC routers and hand held routers equipped with chucks or adapters.



DLCS CHROME COATING:

- Superb wear resistance
- Better chip clearance
- Superior cutting quality
- Less overheating
- More productivity



TOOLBOX
Darbagaldi & Instrumenti
www.TOOLBOX.lv info@toolbox.lv



DLCS CHROME COATING
provides 3 times longer life
than uncoated tools!

Solid Surface and Fiberglass Bit with DLCS Chrome Coating



151 **XTRME**
PERFORMANCE



D mm	I mm	L mm	S mm		ORDER NO. Right-hand rotation
6	19	60	6	10	151.060.19D
6,35	25,4	63,5	6,35	10	151.064.25D
8	25	60	8	10	151.080.25D
12	25	75	12	10	151.120.25D
12,7	38	89	12,7	10	151.127.38D

TECHNICAL DETAILS:

- Premium quality HWM
- Special positively ground cutting edge sharpening for excellent finish
- AlTiN coated

APPLICATION:

for drilling, sizing and jointing fiberglass, phenolic and solid surfaces. The 135° tooth geometry allows vertical feeding minimizing the bending of the workpiece. Can be used on machining centres, point to point machines, CNC routers and hand held routers equipped with chucks or adapters.



DLCS CHROME COATING:

- Superb wear resistance
- Better chip clearance
- Superior cutting quality
- Less overheating
- More productivity

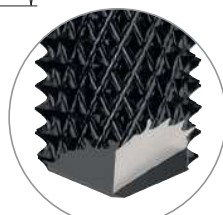

Sharpening
135°



DLCS CHROME COATING
provides 3 times longer life
than uncoated tools!

DP Router Cutters with Negative Shear Angle



Negative Cutting Edge

141 (HWM tool body)

D mm	I mm	L mm	S mm	Z		ORDER NO. Right-hand rotation
6	10	60	6	1 neg.	1	141.260.61
8	15	65	8	1 neg.	1	141.280.61
10	15	65	10	1 neg.	1	141.300.61
12	20	70	12	1 neg.	1	141.320.61

TECHNICAL DETAILS:

- Special super-micrograin carbide formulation
- Straight cutting edge.
- DP (H3).
- Resharpenable cutter (max 3 times).
- Feed speed on MDF 3-4 m/min for cutter Ø6 and Ø8mm and 4-5m/minute for Ø10 and Ø12mm

APPLICATION: to be used on all CNC routers for jointing and sizing of solid wood and wood-based panels.



DP Router Cutters



* Construction Z1+1
for 141.101.61 item

141

D mm	I mm	L mm	S mm	Z		ORDER NO. Right-hand rotation
6	8	65	12x40	1	1	141.060.61
8	12	65	12x40	1	1	141.080.61
*10	22	75	12x40	1+1	1	141.101.61

TECHNICAL DETAILS:

- Super strength steel.
- DP cutting edge (H2,5).
- HW plunging tip for diagonal plunge-cutting.
- Resharpenable cutter (max 3 times).
- Max feed speed 4 m/min.

APPLICATION: to be used on all CNC routers for jointing and sizing of solid wood and wood-based panels.

DP Router Cutters with Shear Angle



140



D mm	I mm	L mm	S mm	Z		ORDER NO. Right-hand rotation
10	25	72	12x40	1+1 (3 DP+1 HW)	1	140.03956
12	27	75	12x40	1+1 (3 DP+1 HW)	1	140.120.61
12	35	85	12x40	1+1 (4 DP+1 HW)	1	140.121.61
12,7	27	75	12,7x40	1+1 (3 DP+1 HW)	1	140.127.61
12,7	35	85	12,7x40	1+1 (4 DP+1 HW)	1	140.128.61
15,87	27	85	15,87x50	1+1 (3 DP+1 HW)	1	140.158.61
15,87	45	103	15,87x50	1+1 (5 DP+1 HW)	1	140.159.61
16	27	85	16x50	1+1 (3 DP+1 HW)	1	140.160.61
16	35	93	16x50	1+1 (4 DP+1 HW)	1	140.161.61
18	27	85	20x50	1+1 (3 DP+1 HW)	1	140.180.61
18	35	95	20x50	1+1 (4 DP+1 HW)	1	140.181.61
18	45	105	20x50	1+1 (5 DP+1 HW)	1	140.182.61
19,05	27	85	19,05x50	1+1 (3 DP+1 HW)	1	140.190.61
19,05	45	105	19,05x50	1+1 (5 DP+1 HW)	1	140.192.61
20	27	85	20x50	1+1 (3 DP+1 HW)	1	140.200.61
20	35	95	20x50	1+1 (4 DP+1 HW)	1	140.201.61
20	45	105	20x50	1+1 (5 DP+1 HW)	1	140.202.61
20	55	115	20x50	1+1 (6 DP+1 HW)	1	140.203.61

TECHNICAL DETAILS:

- Super strength steel.
- DP cutting edge (H2,5).
- HW plunging tip for diagonal plunge-cutting (Z-axis tool entrance).
- Resharpenable cutter (max 3 times).

APPLICATION:

to be used on all CNC routers for jointing, rabbeting, grooving and copying of raw material, melamine and laminates, MDF, HPL and veneered panels.



Results shown in this diagram are purely empirical, based merely on informative and hypothetical calculation. Each application may require different parameters in consideration of materials in use and machining conditions. CMT is not responsible for direct, indirect, incidental or consequential damages resulting from any defect, error or failure due to this diagram.

Ø10-12,7 mm PLASTIC COATED CHIPBOARD

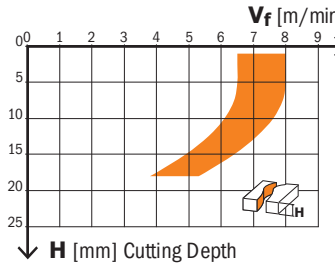

24000 RPM
Correction factor for Vr: MDF=0.8
Veneer across grain=0.7
Chipboard without coating=1.1

Ø15,87-20 mm PLASTIC COATED CHIPBOARD

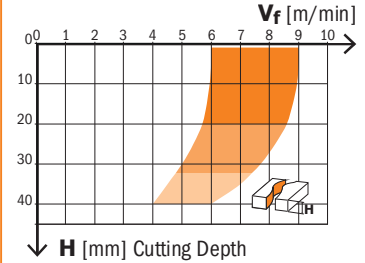

18000 RPM
Correction factor for Vr: MDF=0.8
Veneer across grain=0.7
Chipboard without coating=1.1

DP Router Cutters with 45° Shear Angle

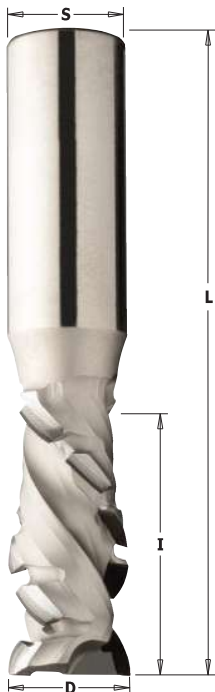

140



D mm	I mm	L mm	S mm	Z		ORDER NO. Right-hand rotation
20	25	85	20x50	1+1 (6 DP+1 HW)	1	140.720.61
20	35	95	20x50	1+1 (8 DP+1 HW)	1	140.721.61
20	45	105	20x50	1+1 (9 DP+1 HW)	1	140.722.61

TECHNICAL DETAILS:

- Super strength steel.
- Diamond cutting edges featuring 45° shear angle (H4).
- HW plunging tip for plunge cutting.
- Resharpenable cutters (max 8-9 times).

APPLICATION:

to be used on all CNC routers for jointing, rabbeting, grooving and copying of raw material, melamine and laminates, MDF, HPL and veneered panels.

Ø20mm PLASTIC COATED CHIPBOARD

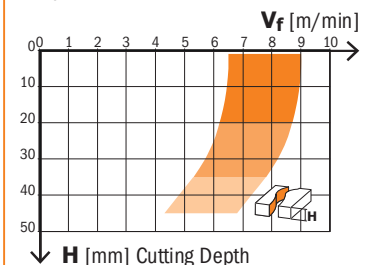

18000 RPM
Correction factor for Vr: MDF=0.8
Veneer across grain=0.7
Chipboard without coating=1.1

DP Router Cutters with Shear Angle

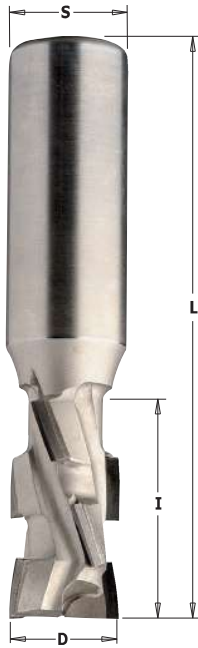

142

D mm	I mm	L mm	S mm	Z		ORDER NO. Right-hand rotation
20	27	85	20x50	2+2 (6 DP+1 HW)	1	142.200.61
20	36	95	20x50	2+2 (8 DP+1 HW)	1	142.201.61
20	45	105	20x50	2+2 (10 DP+1 HW)	1	142.202.61
20	55	115	20x50	2+2 (12 DP+1 HW)	1	142.203.61
25	27	90	25x55	2+2 (6 DP+1 HW)	1	142.250.61
25	36	100	25x55	2+2 (8 DP+1 HW)	1	142.251.61
25	45	110	25x55	2+2 (10 DP+1 HW)	1	142.252.61
25	55	120	25x55	2+2 (12 DP+1 HW)	1	142.253.61

TECHNICAL DETAILS:

- Super strength steel.
- DP cutting edge (H2,5).
- HW plunging tip for diagonal plunge-cutting (Z-axis tool entrance).
- Resharpenable cutter (max 3 times).

APPLICATION:

to be used on all CNC routers for jointing, rabbeting, grooving, copying and dividing cuts of raw material, melamine and laminates, MDF, HPL and veneered panels.

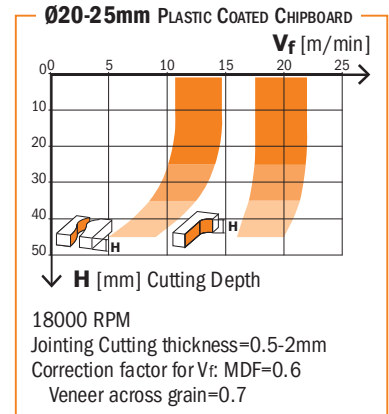

DP Router Cutters with 20° Shear Angle

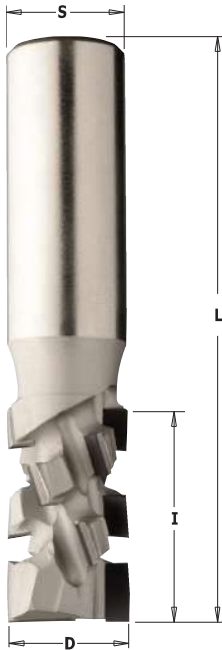

142

D mm	I mm	L mm	S mm	Z		ORDER NO. Right-hand rotation
20	25	85	20x45	2+2 (8 DP+1 HW)	1	142.720.61
20	30	90	20x45	2+2 (10 DP+1 HW)	1	142.721.61
20	35	95	20x45	2+2 (12 DP+1 HW)	1	142.722.61
20	40	100	20x45	2+2 (14 DP+1 HW)	1	142.723.61
20	45	105	20x45	2+2 (16 DP+1 HW)	1	142.724.61
20	50	110	20x45	2+2 (18 DP+1 HW)	1	142.725.61
20	55	115	20x45	2+2 (20 DP+1 HW)	1	142.726.61

TECHNICAL DETAILS:

- Super strength steel.
- Diamond cutting edges featuring 20° shear angle (H4).
- HW plunging tip for diagonal plunge-cutting (Z-axis tool entrance).
- Resharpenable cutters (max 8-10 times).

APPLICATION:

used on all CNC routers for jointing, rabbeting, grooving, copying and dividing raw material, melamine, laminated, MDF, HPL and veneered panels.

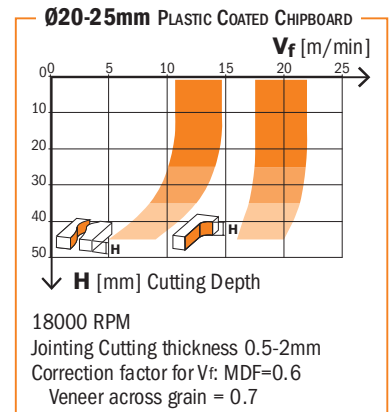

Results shown in this diagram are purely empirical, based merely on informative and hypothetical calculation. Each application may require different parameters in consideration of materials in use and machining conditions. CMT is not responsible for direct, indirect, incidental or consequential damages resulting from any defect, error or failure due to this diagram.

DP Router Cutters with Shear Angle for Nesting (Densimet® Tungsten Heavy Metal Alloys)



143

D mm	I mm	L mm	S mm	Z		ORDER NO. Right-hand rotation
12	25	70	12x40	3 (9 DP)	1	143.120.61
12	31	80	12x40	3 (12 DP)	1	143.121.61

TECHNICAL DETAILS:

- Densimet® tungsten heavy metal alloys for low-vibration.
- DP cutting edge (H2,5).
- Resharpenable cutter (max 6 times).

APPLICATION:

to be used on all CNC routers for jointing, rabbeting, grooving, copying and dividing cuts of raw material, melamine and laminates, MDF, HPL and veneered panels.
High performance on pre-and finish-routing.

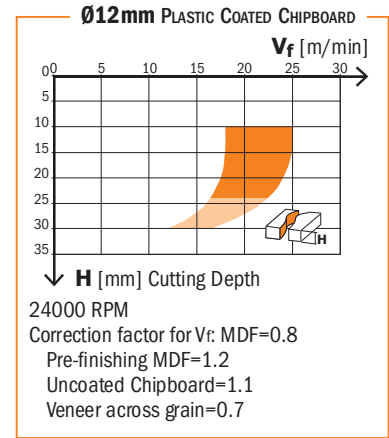

DP Spiral Router Cutters with Shear Angle

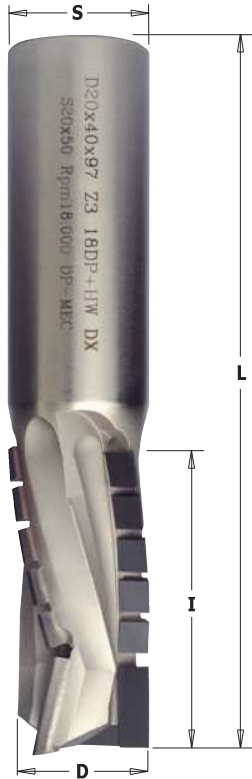

143

D mm	I mm	L mm	S mm	Z		ORDER NO. Right-hand rotation
18	25	82	20x50	3 (10 DP+1 HW)	1	143.180.61
18	30	87	20x50	3 (13 DP+1 HW)	1	143.181.61
18	35	92	20x50	3 (15 DP+1 HW)	1	143.182.61
20	25	82	20x50	3 (10 DP+1 HW)	1	143.200.61
20	30	85	20x50	3 (13 DP+1 HW)	1	143.201.61
20	35	92,5	20x50	3 (15 DP+1 HW)	1	143.202.61
20	40	97	20x50	3 (18 DP+1 HW)	1	143.203.61
20	45	102	20x50	3 (21 DP+1 HW)	1	143.204.61
20	50	106,5	20x50	3 (24 DP+1 HW)	1	143.205.61
20	55	111	20x50	3 (27 DP+1 HW)	1	143.206.61
20	60	116,5	20x50	3 (30 DP+1 HW)	1	143.207.61
20	65	121,5	20x50	3 (31 DP+1 HW)	1	143.208.61
22	30	92	25x50	3 (13 DP+1 HW)	1	143.220.61
22	35	97	25x50	3 (15 DP+1 HW)	1	143.221.61
22	40	102	25x50	3 (18 DP+1 HW)	1	143.222.61
22	45	107	25x50	3 (21 DP+1 HW)	1	143.223.61
22	50	112	25x50	3 (24 DP+1 HW)	1	143.224.61
22	55	117	25x50	3 (27 DP+1 HW)	1	143.225.61
22	60	122	25x50	3 (30 DP+1 HW)	1	143.226.61
22	65	127	25x50	3 (31 DP+1 HW)	1	143.227.61
22	70	132	25x50	3 (36 DP+1 HW)	1	143.228.61

On request

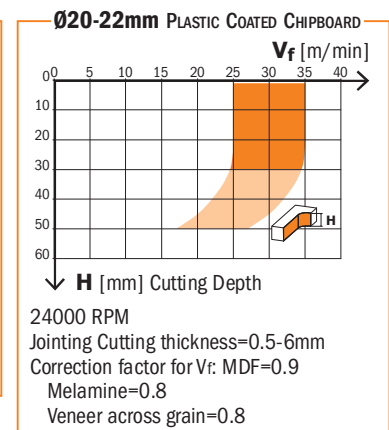
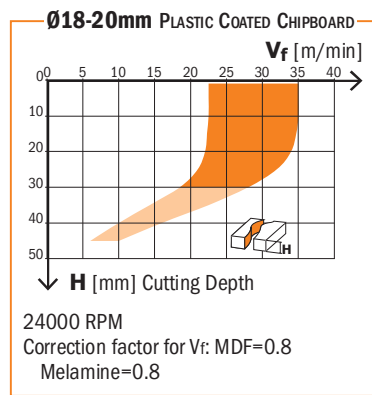

TECHNICAL DETAILS:

- Super strength steel.
- DP cutting edge (H4).
- HW plunging tip for diagonal plunge-cutting (Z-axis tool entrance).
- Resharpenable cutter (max 10/12 times).

APPLICATION:

to be used on all CNC routers for jointing, rabbeting, grooving, copying and dividing cuts of raw material, melamine and laminates, MDF, HPL and veneered panels. High performance on pre-and finish-routing.



Results shown in this diagram are purely empirical, based merely on informative and hypothetical calculation. Each application may require different parameters in consideration of materials in use and machining conditions. CMT is not responsible for direct, indirect, incidental or consequential damages resulting from any defect, error or failure due to this diagram.

DP Router Cutters with 40° Shear Angle



145

DP
Z3+3
Z4+4
RH
40X LONGER LIFE THAN CARBIDE

D mm	I mm	L mm	S mm	Z	1	ORDER NO. Right-hand rotation
□ 50	23	80	25x55	3+3 (9 DP)	1	145.501.61
□ 50	23	80	25x55	4+4 (12 DP)	1	145.511.61
□ 50	28	85	25x55	3+3 (12 DP)	1	145.502.61
□ 50	28	85	25x55	4+4 (16 DP)	1	145.512.61
□ 50	38	95	25x55	3+3 (18 DP)	1	145.503.61
□ 50	38	95	25x55	4+4 (24 DP)	1	145.513.61

□ On request

TECHNICAL DETAILS:

- Super strength steel.
- "H4" diamond cutting edges featuring 40° shear angle.
- Resharpenable cutters (max 8-10 times).
- Maximum feed speed 30m/minute.

APPLICATION:

used on all CNC routers for jointing, rabbeting, grooving, copying and dividing raw material, melamine, laminated, MDF, HPL and veneered panels. High performance routing.

TOOLBOX
Darbagaldi & Instrumenti

www.TOOLBOX.lv info@toolbox.lv

Solid Carbide Router Cutters

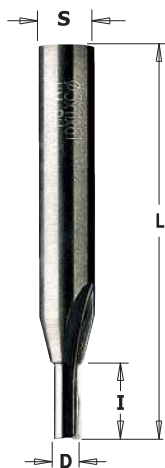

174



D mm	I mm	L mm	S mm		ORDER NO. Right-hand rotation
3	10	55	8	10	174.030.11
4	10	55	8	10	174.040.11
5	12	55	8	10	174.050.11
6	14	55	8	10	174.060.11
7	20	55	8	10	174.070.11

TECHNICAL DETAILS:

- Premium quality HWM.
- 2 radial relief cutting edges [Z2].

Router Cutters



174



D mm	I mm	L mm	S mm		ORDER NO. Right-hand rotation
8	20	55	8	10	174.080.11
8	30	70	8	10	174.081.11
8	40	90	8	10	174.082.11
9	20	55	8	10	174.090.11
10	20	60	8	10	174.100.11
10	30	70	8	10	174.102.11
10	40	90	8	10	174.101.11
11	20	60	8	10	174.110.11
12	20	60	8	10	174.120.11
12	30	70	8	10	174.122.11
12	40	90	8	10	174.121.11
13	20	60	8	10	174.130.11
14	20	60	8	10	174.140.11
14	30	70	8	10	174.142.11
14	40	90	8	10	174.141.11
15	20	60	8	10	174.150.11
16	20	70	8	10	174.160.11
16	30	70	8	10	174.162.11
16	40	90	8	10	174.161.11
18	20	70	8	10	174.180.11
18	30	70	8	10	174.181.11
18	40	80	8	10	174.182.11
19	20	70	8	10	174.190.11
20	20	70	8	10	174.200.11
20	30	70	8	10	174.201.11
20	40	90	8	10	174.202.11
22	20	70	8	10	174.220.11
22	30	70	8	10	174.221.11
22	40	90	8	10	174.222.11
23,5	20	70	8	10	174.235.11
24	20	70	8	10	174.240.11
24	30	70	8	10	174.241.11
24	40	90	8	10	174.242.11
25	20	70	8	10	174.250.11
26	20	70	8	10	174.260.11
26	30	70	8	10	174.261.11
28	20	70	8	10	174.280.11
28	30	70	8	10	174.281.11
29	20	70	8	10	174.290.11
30	20	70	8	10	174.300.11

HW plunge centre tip



TECHNICAL DETAILS:

- Super strength steel.
- 2 precision ground HW cutting edges and 1 HW plunge centre tip [Z2+1].

APPLICATION:

used for drilling, grooving or jointing on solid wood and wood composites.
Can be used on machining centres, CNC routers and hand-held routers equipped with chucks or adapters.



Solid Carbide Router Cutters

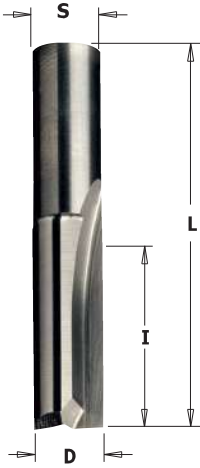

112



D mm	I mm	L mm	S mm	PACK QTY.	ORDER NO. Right-hand rotation
3	10	48	9,5	50	112.030.11
4	10	48	9,5	50	112.040.11
5	12	39	9,5	50	112.050.11
6	14	41	9,5	50	112.060.11
7	16	43	9,5	50	112.070.11
8	18	48	9,5	50	112.080.11
8	30	60	9,5	50	112.081.11
9	20	52	9,5	50	112.090.11
10*	22	52	9,5	50	112.100.11
10*	35	65	9,5	50	112.101.11
11*	26	52	9,5	10	112.110.11
12*	26	52	9,5	10	112.120.11

* Super strength steel
2 precision ground HW cutting edges [Z2+1]

TECHNICAL DETAILS:

- Premium quality HWM.
- 2 radial relief cutting edges [Z2+1].

HW plunge centre tip



TOOLBOX
Darbagaldi & Instrumenti
www.TOOLBOX.lv info@toolbox.lv

Router Cutters



113



D mm	I mm	L mm	S mm	PACK QTY.	ORDER NO. Right-hand rotation
12	26	52	12	10	113.120.11
12	40	70	12	10	113.121.11
13	26	52	12	10	113.130.11
14	28	56	12	10	113.140.11
14	40	72	12	10	113.141.11
15	32	60	12	10	113.150.11
16	32	60	12	10	113.160.11
16	40	72	12	10	113.161.11
17	35	64	12	10	113.170.11
18	35	64	12	10	113.180.11
19	38	68	12	1	113.190.11
20	38	68	12	1	113.200.11
22	40	72	12	1	113.220.11
24	40	72	12	1	113.240.11
25	40	72	12	1	113.250.11
26	42	74	12	1	113.260.11
28	42	74	12	1	113.280.11
30	42	74	12	1	113.300.11

TECHNICAL DETAILS:

- Super strength steel.
- 2 precision ground HW cutting edges and 1 HW plunge centre tip [Z2+1].

APPLICATION:

used for grooving, jointing and routing on solid wood, wood composites, plastic materials and laminates.

HW plunge centre tip



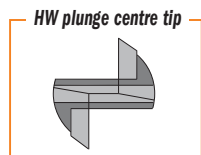

TECHNICAL DETAILS:

- Premium quality HWM.
- 2 radial relief cutting edges [Z2].
- 1 HW [Z1] plunge centre tip.

APPLICATION:

for grooving, jointing and routing on solid wood, wood composites, plastic materials and laminates.



175



D mm	I mm	L mm	S mm	PACK Qty.	ORDER NO. Right-hand rotation
• 4	10	65	10	50	175.040.11
• 5	12	65	10	50	175.050.11
• 6	14	65	10	50	175.060.11
• 7	17	65	10	50	175.070.11
8	20	65	10	50	175.080.11
10	25	70	10	50	175.100.11
12	25	70	10	10	175.120.11
14	25	70	10	10	175.140.11
15	25	70	10	10	175.150.11
16	25	70	10	10	175.160.11
18	25	70	10	10	175.180.11
20	25	70	10	10	175.200.11
22	25	70	10	10	175.220.11
24	25	70	10	10	175.240.11
25	25	70	10	10	175.250.11
26	25	70	10	10	175.260.11
30	25	70	10	10	175.300.11
35	25	70	10	10	175.350.11

• HWM

176



D mm	I mm	L mm	S mm	PACK Qty.	ORDER NO. Right-hand rotation
10	40	87	10	10	176.100.11
12	40	87	10	10	176.120.11
14	40	87	10	10	176.140.11
15	40	87	10	10	176.150.11
16	40	87	10	10	176.160.11
18	40	87	10	10	176.180.11
20	40	87	10	10	176.200.11

177



D mm	I mm	L mm	S mm	PACK Qty.	ORDER NO. Right-hand rotation
10	35	90	12	10	177.100.11
12	35	90	12	10	177.120.11
12	50	100	12	10	177.121.11
14	35	90	12	10	177.140.11
16	35	90	12	10	177.160.11
16	60	110	12	10	177.161.11
18	35	90	12	10	177.180.11
18	60	110	12	10	177.181.11
20	35	90	12	10	177.200.11
22	35	90	12	10	177.220.11
24	35	90	12	10	177.240.11
25	35	90	12	10	177.250.11
26	35	90	12	10	177.260.11
28	35	90	12	10	177.280.11
30	35	90	12	10	177.300.11
35	35	90	12	10	177.350.11

TECHNICAL DETAILS:

- Super strength steel.
- 2 precision ground HW cutting edges and 1 HW plunge centre tip [Z2+1].

APPLICATION:

used for grooving, jointing and general routing operation on solid wood, wood composites, plastics and laminates. Can be used on machining centres, CNC routers and hand-held routers.



Straight Router Cutters with Insert Knives



653



D mm	I mm	L mm	S mm	SPARE KNIVES		Box	ORDER NO. Right-hand rotation
				Side	Top		
16	28,3	92	20	790.283.12	790.075.00	10	653.661.11
16	48,3	111,5	20	790.483.12	790.075.00	10	653.662.11
18	48,3	111,5	20	790.483.12	790.075.00	10	653.681.11
20	48,3	111,5	20	790.483.12	790.096.00	10	653.701.11

Spare parts

790.075.00	7,5x12x1,5mm knife
790.096.00	9,6x12x1,5mm knife
790.283.12	28,3x12x1,5mm knife
790.483.12	48,3x12x1,5mm knife
990.072.00	M3,5x3,5mm Torx screw
990.074.00	M4x3,5mm Torx screw
990.075.00	M4x6mm Torx screw
991.061.00	T15 Torx key

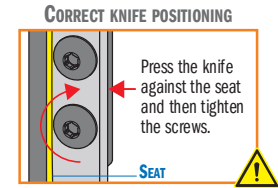

TECHNICAL DETAILS:

- Super strength steel.
- 2 cutting edges [Z1+1].

APPLICATION:

straight router bit with one replaceable plunging knife and one-sided knife fixed by special Torx screws. The body is precision balanced. For finishing and routing, plunge cutting and grooving in board materials (laminated chipboards, MDF) and hardwood. For use on CNC machining centres.

Spoilboard Surfacing Router Cutters with Insert Knives



663



D mm	I mm	L mm	Z	S mm	Box	ORDER NO. Right-hand rotation	Spare parts	
							TE	Hex nut
new 35	10,5	60	3	8x38	1	663.007.11	790.105.03	990.078.00
38	12	60	3	12x35	1	663.005.11	790.120.03	990.075.00
60	12	80	3	12x50	1	663.004.11	790.120.03	990.075.00
80	12	90	3	20x60	1	663.003.11	790.120.03	990.075.00
new 100	12	90	4	20x50	1	663.006.11	790.120.03	990.075.00

Spare parts

991.061.00	T15 Torx key
990.036.00	M8x25mm TE screw (for 663.003.11 and 663.006.11)
990.020.00	Hex nut for threaded arbors M8 (for 663.003.11 and 663.006.11)

TECHNICAL DETAILS:

- Super strength steel.
- 3 cutting edges [Z3].

APPLICATION:

the new router bit for CNC routers is ideal for fast removal of material over a large surface area leaving an improved finish at the bottom of the cut. Used on soft and hardwood, particle board and MDF. The cutter uses 4-sided inserts in super micrograin carbide.

A cost effective solution compared to brazed router bits and solid carbide spiral bits.

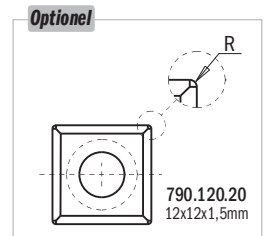

TOOLBOX
 Darbagaldi & Instrumenti
 www.TOOLBOX.lv info@toolbox.lv

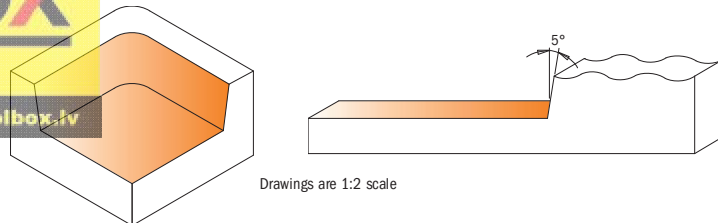

Drawings are 1:2 scale

Xtreme Plunge CNC Cutters with Insert Knives

new

CMT ORANGE TOOLS



653 XTREME

D mm	I mm	L mm	S mm	SPARE KNIVES		10	ORDER NO. Right-hand rotation
				Side	Top		
40	29,5	100	20	790.295.12	790.120.00		653.001.11

- Spare parts**
- 790.120.00 12x12x1,5mm knife
 - 790.295.12 29,5x12x1,5mm knife
 - 990.075.00 M4x6mm Torx screw
 - 991.061.00 T15 Torx key
 - 990.036.00 M8x25mm TE screw
 - 990.020.00 Hex nut for threaded arbors M8

TECHNICAL DETAILS:
 - Super strength steel.
 - 2 cutting edges [Z2+2].

APPLICATION:
 The new CNC cutter is designed with 2 plunging knives and two-sided knives fixed by special Torx screws. It is ideal for direct plunge into the material and fast removal over a large surface area leaving an improved finish at the bottom of the cut.
 Use on soft and hardwood, particle board, melamine and MDF.
 For use on CNC machining centres only.

CORRECT KNIFE POSITIONING

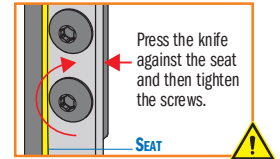

Universal Profile Cutter for CNC Machines



663.301

D mm	I mm	L mm	S mm	1	ORDER NO. Right-hand rotation

- Spare parts**
- 692.999.01 38x15x16mm wedge for cutter
 - 990.068.00 M5x5mm TCEI screw
 - 991.064.00 Hex key 4mm

TECHNICAL DETAILS:
 - Super Strength steel.
 - 2 cutting edges [Z2]
 for knives 40x4mm and 50x4mm.

APPLICATION:
 for universal profiling of solid wood on CNC router machines. For cutting width 40mm and 50mm (serie 690). Profile knives may only be ordered and used in pairs. For router machines with mechanical feed.

USEFUL TIPS: for enhanced safety, when using 50mm knives, it is recommended to carry out the cut in several passes.

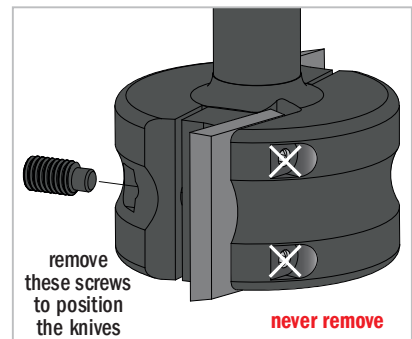

TO BE USED WITH SP KNIVES SERIES 690 (SEE PAGE 116~129)

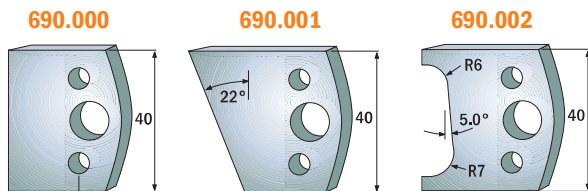

Profile knives cutting length=40mm (serie 690)

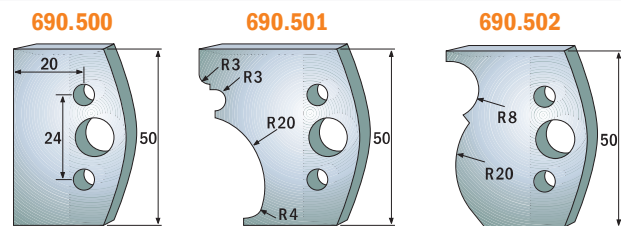

Profile knives cutting length=50mm (serie 690.5)

Adjustable Chamfering CNC Cutter



663.201



D mm	D_Max 45° mm	I mm	A	L mm	S mm	ORDER NO.
85	102	39,5	0°-45° - 0°+90°	92	20	663.201.11

Spare parts

790.395.12	39,5x12x1,5mm knife
663.999.01	38x6x12mm wedge
990.087.00	M6x8mm STEI screw (4x2mm threaded pin)
991.067.00	3mm hex key
663.999.02	Kit with 2 wedges and 1 screw for blocking rotation
990.099.00	M8x25mm TCEI screw
990.023.00	M8 (4mm) nut
991.081.00	4mm "T" hex key

TECHNICAL DETAILS:

- Tool body in steel
- 2 reversible HWM knives 39,5x12x1,5mm [Z2]
- Peripheral cutting on both sides
- Adjustable swivelling blade (Rotates at 7,5° intervals; Precision = 7,5°)
- Swivelling range 0-45° towards top, and 0-90° towards bottom

APPLICATION:

for jointing, rebating and chamfering of solid wood and wooden boards. Suitable for CNC router machines and stationary router machine with manual or mechanical feed.

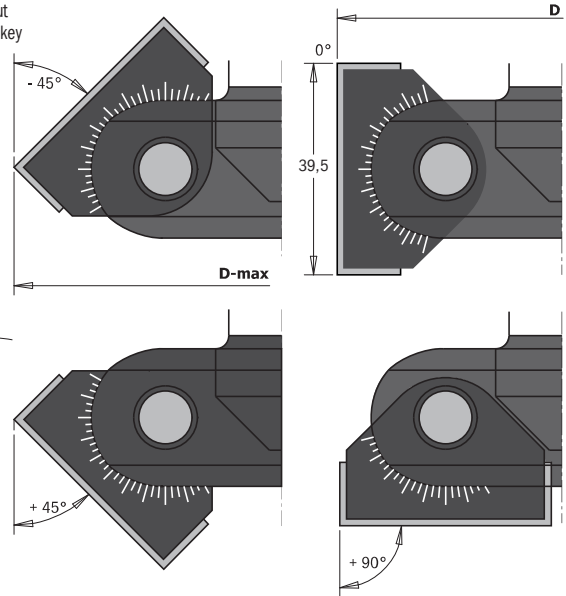
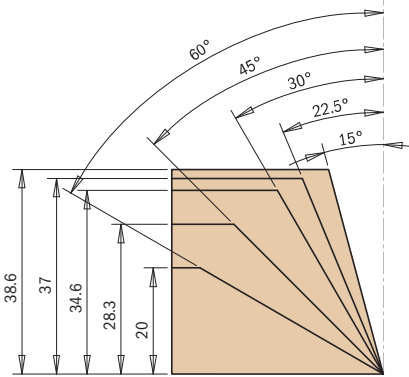

V-Groove - Folding - Signmaking CNC Router Cutters with Insert Knives



663.1



D mm	I mm	L mm	A	S mm	Z	ORDER NO.
33	40	125	45°	20	1	663.103.11
44	38	115	60°	20	1	663.102.11
52	25	100	91°	20	1	663.101.11
60	21	95	110°	20	1	663.110.11
87	24	95	120°	20	2	663.120.11
91	20	95	130°	20	2	663.130.11
96,5	12,4	95	150°	20	2	663.150.11

Spare parts

990.073.00	M3,5x5x7,2mm Torx T15 screw (for 790.580.01)
990.075.00	M4x6x8,2mm Torx T15 screw
991.061.00	T15 Torx key
990.036.00	M8x25mm TE screw
990.020.00	Hex nut for threaded arbors M8

Optional S790.360.03 36x12x1,5mm HW-SMG replaceable knife (4 cutting edges 35°)

CORRECT KNIFE POSITIONING

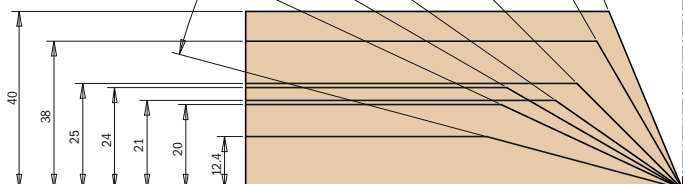
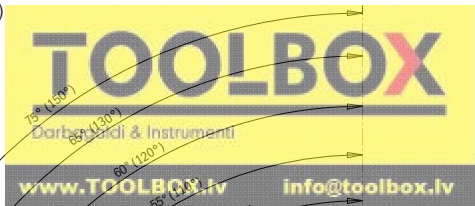
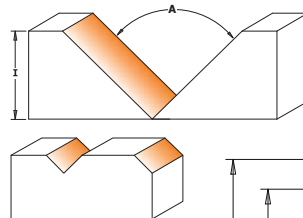
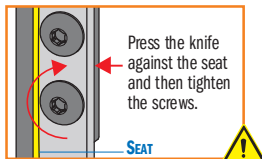

APPLICATION:

this innovative CNC router bit offers you an endless range of possibilities for V-Groove, miter folds, signmaking, lettering and chamfer edges. The tool mounts a high grade HWM reversible knife ideal for general purpose, chipboard and plywood, but a higher quality is available for laminated and MDF material.

Complete Set for Decorating on MDF



616.000.01

This unique system includes a tool body with 22 profile knives designed for multiple applications on your CNC routers. Ideal for MDF, laminates, veneers, plastic, wood and solid surface materials.

TECHNICAL DETAILS:

Knives 20x20x2mm.

We recommend re-sharpening the knives on profile cutting edge.

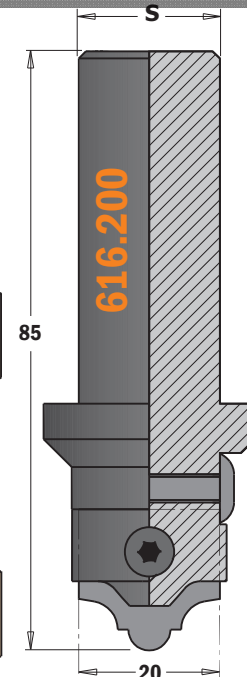
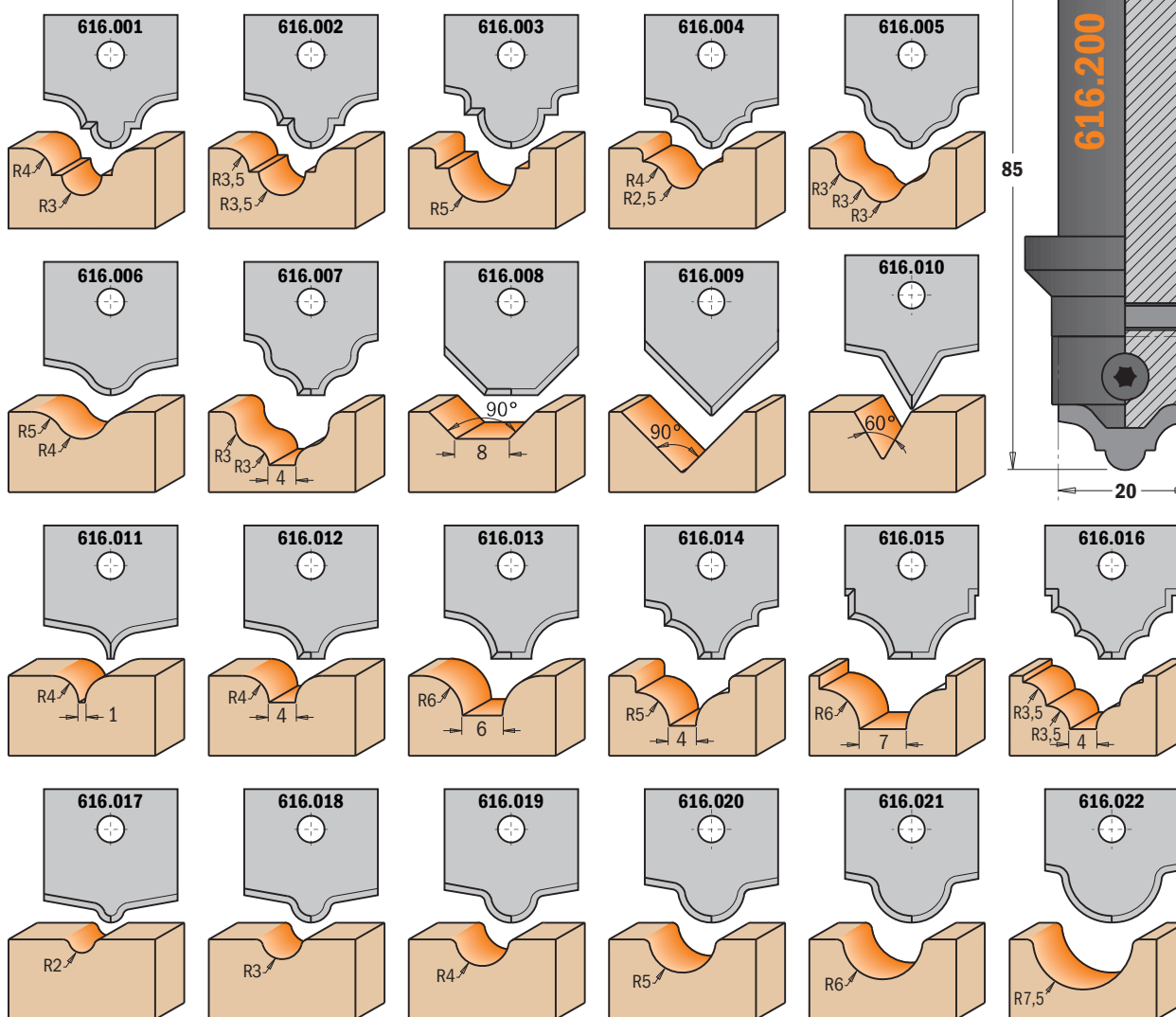

Drawings are 1:1 scale

DESCRIPTION	S mm		ORDER NO. Right-hand rotation			
Complete Set for Decorating on MDF	20	10	616.000.01	616.200	990.077.00	991.061.00
Router cutter body with shank Ø20mm (insert knives not included)	20	10	616.200		990.077.00	991.061.00
Router cutter body with shank Ø12mm (insert knives not included)	12	10	616.120		990.077.00	991.061.00

REMARK: tool body and insert knives can be sold individually.

Complete Set for MDF Doors



615.004.01

Open some new doors with CMT. Our 4-piece set includes the most popular profile to make MDF panel doors for kitchens and bathrooms. Each bit is made from bar stock steel and is equipped with 5 different profile knives allowing enormous possibilities for easy and economical construction. The highest materials, the lowest tolerance in balancing and the precision in the sharpening of the knives let you obtain a smooth finish on your CNC machine.

- Spare parts**
- 991.061.00 T15 Torx key
 - 990.073.00 M3,5x5mm Torx screw
 - 990.075.00 M4x6mm Torx screw
 - 990.077.00 M3,5x7mm Torx screw

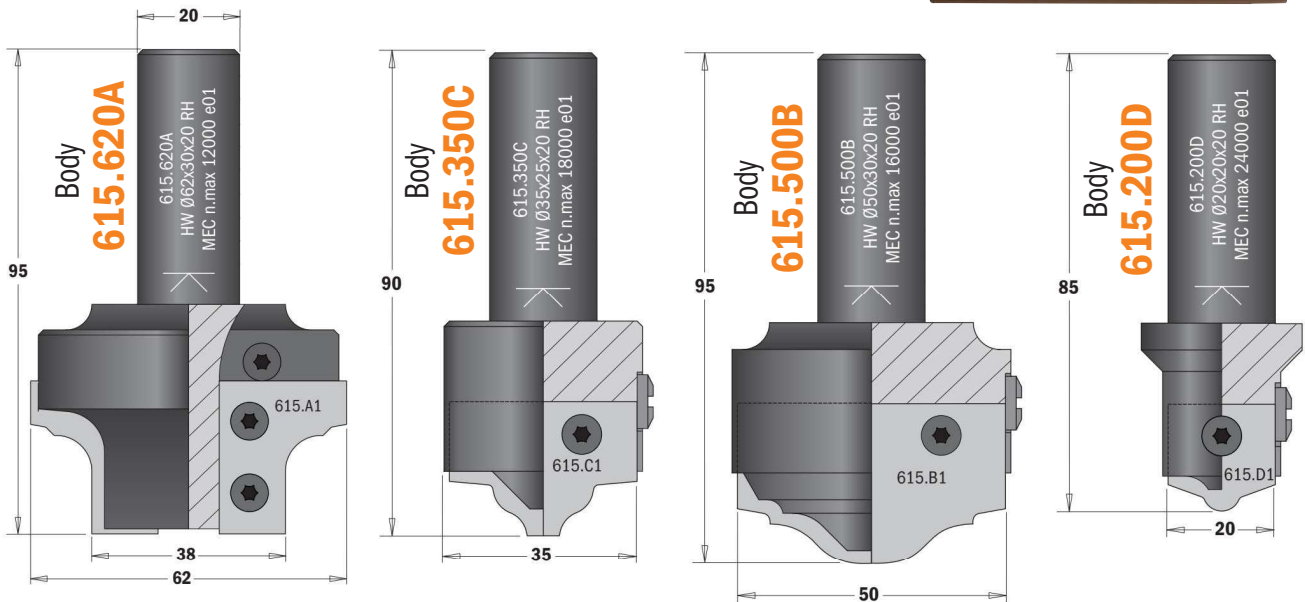

Standard Profile No. 1

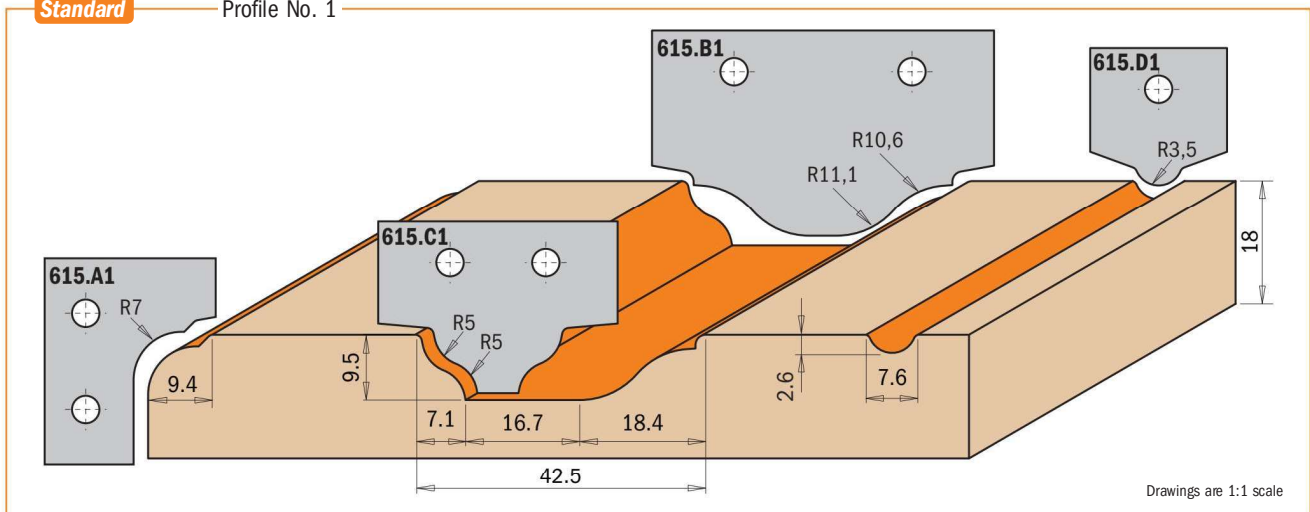

Drawings are 1:1 scale

DESCRIPTION	S mm	ORDER NO.
Complete Set for MDF Doors (Profile no. 1)	20	Right-hand rotation 615.004.01



Optional

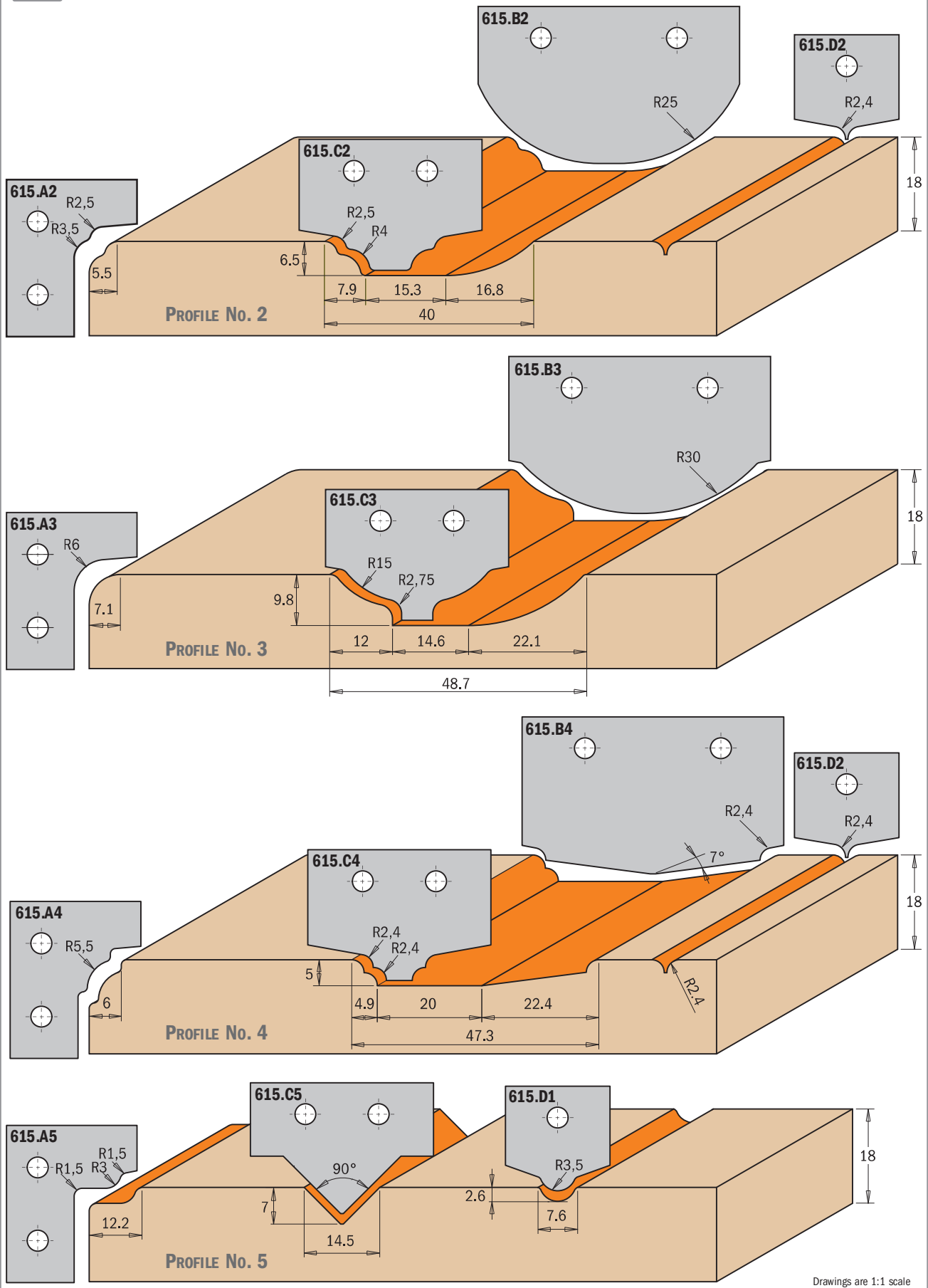

Drawings are 1:1 scale

Slot Mortising Bits with Chip-Breaker

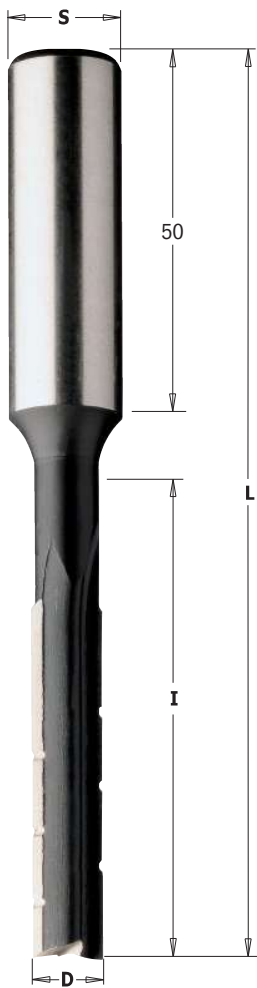

102

D mm	I mm	L mm	S mm		ORDER NO. Right-hand rotation	ORDER NO. Left-hand rotation
6	50	105	16	10	102.060.31	102.060.32
7	55	110	16	10	102.070.31	102.070.32
8	60	115	16	10	102.080.31	102.080.32
9	65	120	16	10	102.090.31	102.090.32
10	70	125	16	10	102.100.31	102.100.32
11	75	130	16	10	102.110.31	102.110.32
12	80	135	16	10	102.120.31	102.120.32
13	85	140	16	10	102.130.31	102.130.32
14	90	145	16	10	102.140.31	102.140.32
15	95	150	16	10	102.150.31	102.150.32
16	100	155	16	10	102.160.31	102.160.32
17	105	160	16	10	102.170.31	102.170.32
18	110	165	16	10	102.180.31	102.180.32
19	115	170	16	10	102.190.31	102.190.32
20	120	175	16	10	102.200.31	102.200.32
22	125	180	16	10	102.220.31	102.220.32
24	125	180	16	10	102.240.31	102.240.32

172

D mm	I mm	L mm	S mm		ORDER NO. Right-hand rotation	ORDER NO. Left-hand rotation
6	50	105	13	10	172.060.31	172.060.32
7	55	110	13	10	172.070.31	172.070.32
8	60	115	13	10	172.080.31	172.080.32
9	65	120	13	10	172.090.31	172.090.32
10	70	125	13	10	172.100.31	172.100.32
11	75	130	13	10	172.110.31	172.110.32
12	80	135	13	10	172.120.31	172.120.32
13	85	140	13	10	172.130.31	172.130.32
14	90	145	13	10	172.140.31	172.140.32
15	95	150	13	10	172.150.31	172.150.32
16	100	155	13	10	172.160.31	172.160.32
18	110	165	13	10	172.180.31	172.180.32
20	120	175	13	10	172.200.31	172.200.32

TECHNICAL DETAILS:

- Long-lasting cutting performance.
- 2 HL precision ground straight cutting edges with chip-breaker teeth [Z2R].

APPLICATION:

for cutting mortise slots in soft and hardwood. Used on machining centres equipped with chucks.

MACHINING DEEP SLOTS GUIDE

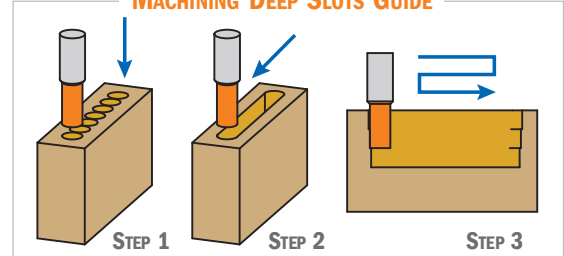

TOOLBOX

Darbagalki & Instrumenti

www.TOOLBOX.lv info@toolbox.lv

6-Piece Mortising Bit Sets

102-172



Ideal for heavy mortise jobs. Made of super strength high speed steel and available in left-hand or right-hand rotation. Safely packaged in a hardwood and glass box for protection, these sets are economical and a perfect addition to any workshop.



S mm	D mm		ORDER NO. Right-hand rotation	ORDER NO. Left-hand rotation
16	6-8-10-12-14-16	1	102.001.00	102.001.10
13	6-8-10-12-14-16	1	172.001.00	172.001.10

Twisted Slot Mortising Bits with Chip-Breaker

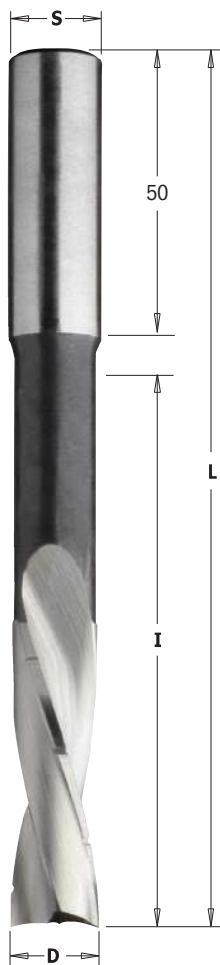

161



D mm	I mm	L mm	S mm		ORDER NO. Right-hand rotation	ORDER NO. Left-hand rotation
6	60	120	16	10	161.060.31	161.060.32
8	70	130	16	10	161.080.31	161.080.32
10	80	140	16	10	161.100.31	161.100.32
12	90	150	16	10	161.120.31	161.120.32
14	100	160	16	10	161.140.31	161.140.32
16	110	170	16	10	161.160.31	161.160.32

160



D mm	I mm	L mm	S mm		ORDER NO. Right-hand rotation	ORDER NO. Left-hand rotation
6	60	120	13	10	160.060.31	160.060.32
8	70	130	13	10	160.080.31	160.080.32
10	80	140	13	10	160.100.31	160.100.32
12	90	150	13	10	160.120.31	160.120.32
14	100	160	13	10	160.140.31	160.140.32
16	110	170	13	10	160.160.31	160.160.32

TECHNICAL DETAILS:

- Long-lasting cutting performance.
- 2 HSS precision ground twisted cutting edges with chip-breaker teeth [Z2R].

APPLICATION:

for cutting mortise slots in soft and hardwood. Used on machining centres equipped with chucks. RPM 3000~5000

MACHINING DEEP SLOTS GUIDE

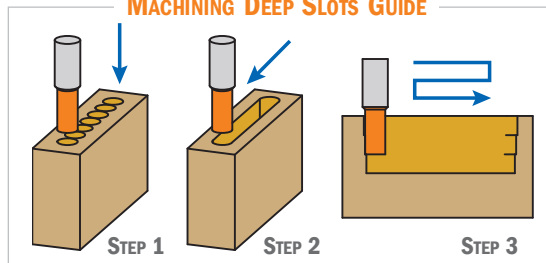

6-Piece Mortising Bit Sets

160-161



Ideal for heavy mortise jobs. Made of super strength high speed steel and available in left-hand or right-hand rotation. Safely packaged in a hardwood and glass box for protection, these sets are economical and a perfect addition to any workshop.



S mm	D mm		ORDER NO. Right-hand rotation	ORDER NO. Left-hand rotation
16	6-8-10-12-14-16	1	161.001.00	161.001.10
13	6-8-10-12-14-16	1	160.001.00	160.001.10

Slot & Mortise Boring Bits



164



D mm	L mm	S mm		ORDER NO. Right-hand rotation
18	100	M12x1	1	164.180.11
20	100	M12x1	1	164.200.11
22	100	M12x1	1	164.220.11

TECHNICAL DETAILS:

- Super strength steel.
- HW cutting head with precision balanced centre point.
- 2 HW precision ground cutting edges [Z2].
- 2 negatively ground spurs [V2].

APPLICATION:

used for drilling blind holes in solid wood, wood composites, plastic and laminated materials. Used on slot and mortise machines equipped with chucks.

TOOLBOX
 Darbagaldi & Instrumenti
www.TOOLBOX.lv info@toolbox.lv

Slot & Mortise Boring Bits

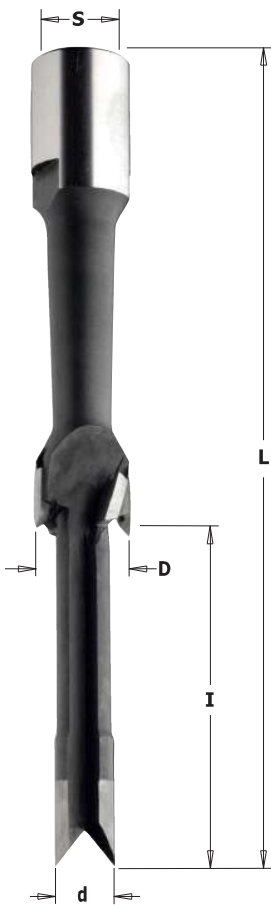

166-167



d mm	D mm	I mm	L mm	S mm		ORDER NO. Right-hand rotation
11	22	62	155	M12x1	1	166.220.11
12	19	62	155	M12x1	1	167.190.11

TECHNICAL DETAILS:

- Super strength steel.
- 2 HW precision ground cutting edges [Z2].
- 2 negatively ground spurs [V2].

APPLICATION:

used for drilling and cutting mortise slots in solid wood, wood composites, plastic and laminated materials.

Slot & Mortise Boring Bits



163



D mm	L mm	S mm		ORDER NO. Right-hand rotation
12	100	M12x1	1	163.120.11
14	100	M12x1	1	163.140.11
16	100	M12x1	1	163.160.11

TECHNICAL DETAILS:

- Super strength steel.
- 2 HW precision ground cutting edges [Z2].

APPLICATION:

used for cutting mortises and slots in solid wood and wood composites. Assembled in chucks.

Carbide Spiral Slot Mortising Bits with Chip-Breaker



161



D mm	I ₁ mm	I mm	L mm	S mm		ORDER NO. Right-hand rotation	ORDER NO. Left-hand rotation
12	25	75	150	16x50	10	161.120.11	161.120.12
16	25	95	170	16x50	10	161.160.11	161.160.12

TECHNICAL DETAILS:

- Long-lasting cutting performance.
- Super strength steel.
- 2 precision ground HW cutting edges with chip-breaker teeth and 1 HW plunge centre tip [Z2+1].

APPLICATION:

for cutting mortise slots in soft and hardwood. Used on machining centres equipped with chucks. RPM 3000-5000

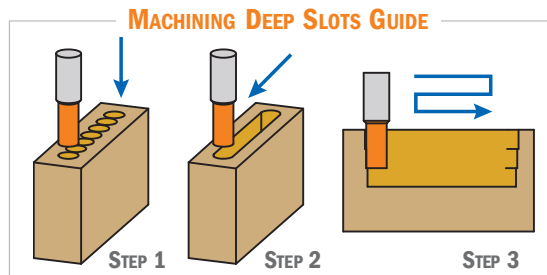
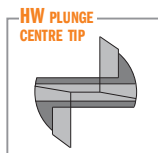

Reciprocating Slot Mortising Bits

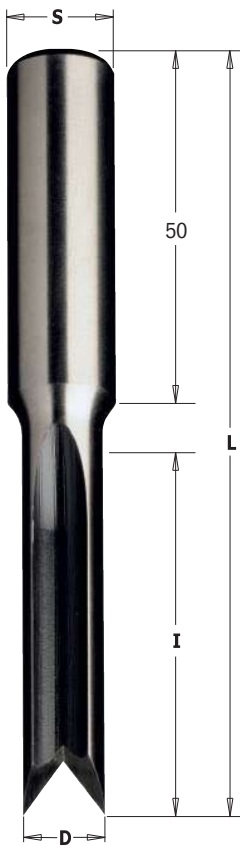

103



D mm	I mm	L mm	S mm		ORDER NO. Right-hand & Left-hand rotation
6	45	100	16	1	103.060.30
7	45	100	16	1	103.070.30
8	45	100	16	1	103.080.30
9	45	100	16	1	103.090.30
10	55	110	16	1	103.100.30
11	55	110	16	1	103.110.30
12	55	110	16	1	103.120.30
13	55	110	16	1	103.130.30
14	55	110	16	1	103.140.30
15	55	110	16	1	103.150.30
16	55	110	16	1	103.160.30

TECHNICAL DETAILS:

- Long-lasting cutter performance.
- 2 HL precision ground cutting edges [Z2].

APPLICATION:

used for cutting mortise slots in soft and hardwood. Used on machining centres equipped with chucks.

Reciprocating Slot Mortising Bits

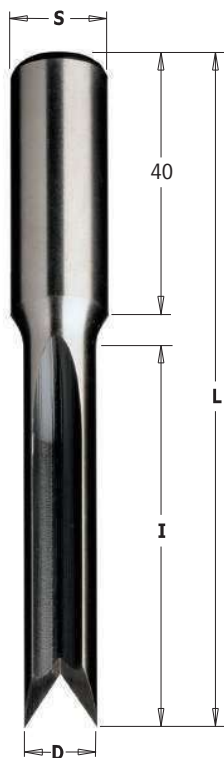

179



D mm	I mm	L mm	S mm		ORDER NO. Right-hand & Left-hand rotation
6	45	90	13	1	179.060.50
7	50	95	13	1	179.070.50
8	50	95	13	1	179.080.50
9	55	100	13	1	179.090.50
10	60	105	13	1	179.100.50
11	65	110	13	1	179.110.50
12	70	115	13	1	179.120.50
13	75	120	13	1	179.130.50

TECHNICAL DETAILS:

- Long-lasting cutter performance.
- 2 HSS precision ground cutting edges [Z2].

APPLICATION:

used for cutting mortise slots in soft and hardwood. Used on machining centres equipped with chucks.

TOOLBOX
 Darbagaldi & Instrumenti
www.TOOLBOX.lv info@toolbox.lv

Reciprocating Slot Mortising Bits

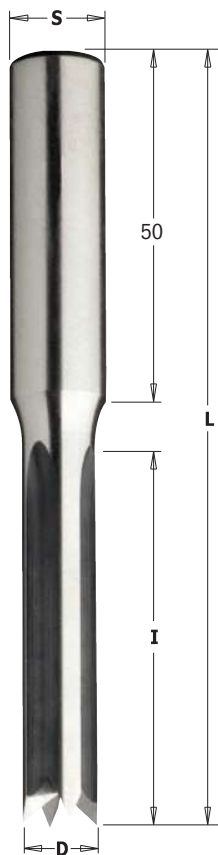

104



D mm	I mm	L mm	S mm		ORDER NO. Right-hand & Left-hand rotation
6	45	100	13	1	104.060.30
7	45	100	13	1	104.070.30
8	45	100	13	1	104.080.30
9	45	100	13	1	104.090.30
10	55	110	13	1	104.100.30
11	55	110	13	1	104.110.30
12	55	110	13	1	104.120.30
13	55	110	13	1	104.130.30
14	55	110	13	1	104.140.30
15	55	110	13	1	104.150.30
16	55	110	13	1	104.160.30

TECHNICAL DETAILS:
 - Long-lasting cutting performance.
 - 4 HL precision ground cutting edges [Z4].

APPLICATION:
 used for cutting mortise slots in soft and hardwood.
 Used on machining centres equipped with chucks.

Reciprocating Slot Mortising Bits

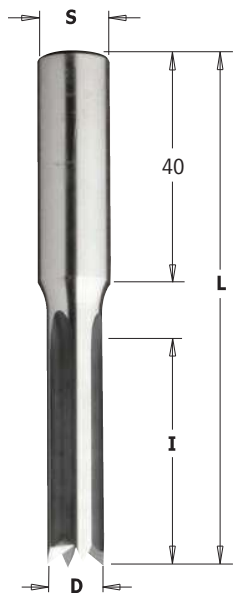

105



D mm	I mm	L mm	S mm		ORDER NO. Right-hand & Left-hand rotation
6	28	73	10	1	105.060.30
7	28	73	10	1	105.070.30
8	28	73	10	1	105.080.30
9	28	73	10	1	105.090.30
10	28	73	10	1	105.100.30
11	28	73	10	1	105.110.30
12	28	73	10	1	105.120.30
13	28	73	10	1	105.130.30
14	28	73	10	1	105.140.30
15	28	73	10	1	105.150.30
16	28	73	10	1	105.160.30

TECHNICAL DETAILS:
 - Long-lasting cutting performance.
 - 4 HL precision ground cutting edges [Z4].

APPLICATION:
 used for cutting mortise slots in soft and hardwood.
 Used on machining centres equipped with chucks.

Reciprocating Slot Mortising Bits

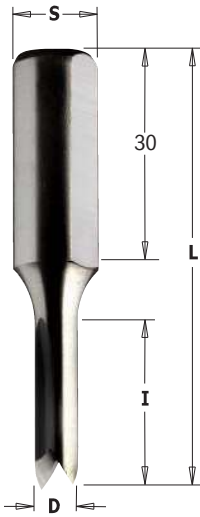

106



D mm	I mm	L mm	S mm	Z		ORDER NO. Right-hand & Left-hand rotation
6	25	60	12	2	1	106.060.30
7	25	60	12	2	1	106.070.30
8	25	60	12	2	1	106.080.30
9	25	60	12	2	1	106.090.30
10	25	60	12	4	1	106.100.30
11	25	60	12	4	1	106.110.30
12	25	60	12	4	1	106.120.30
13	25	60	12	4	1	106.130.30
14	25	60	12	4	1	106.140.30
15	25	60	12	4	1	106.150.30

TECHNICAL DETAILS:

- Long-lasting cutter performance.
- 2 or 4 HL precision ground cutting edges [Z2-Z4].
- Parallel shank with driving flat.

Slot Mortising Bits

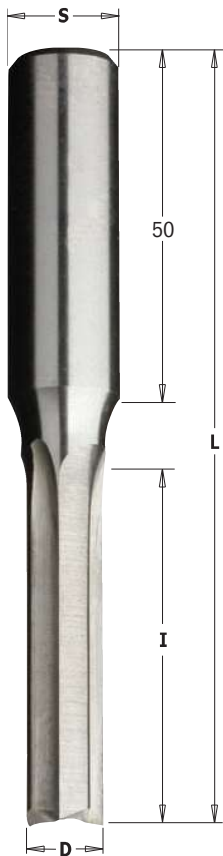

107



D mm	I mm	L mm	S mm		ORDER NO. Right-hand rotation	ORDER NO. Left-hand rotation
6	55	110	16	1	107.060.31	107.060.32
8	55	110	16	1	107.080.31	107.080.32
10	55	110	16	1	107.100.31	107.100.32
12	55	110	16	1	107.120.31	107.120.32
14	60	115	16	1	107.140.31	107.140.32
16	60	115	16	1	107.160.31	107.160.32
18	60	115	16	1	107.180.31	107.180.32
20	60	115	16	1	107.200.31	107.200.32

TECHNICAL DETAILS:

- Long-lasting cutter performance.
- 3 HL precision ground cutting edges [Z3].

APPLICATION:

used for cutting mortise slots in soft and hardwood.
Used in machining centres equipped with chucks.

INDUSTRIAL DOWEL DRILLS

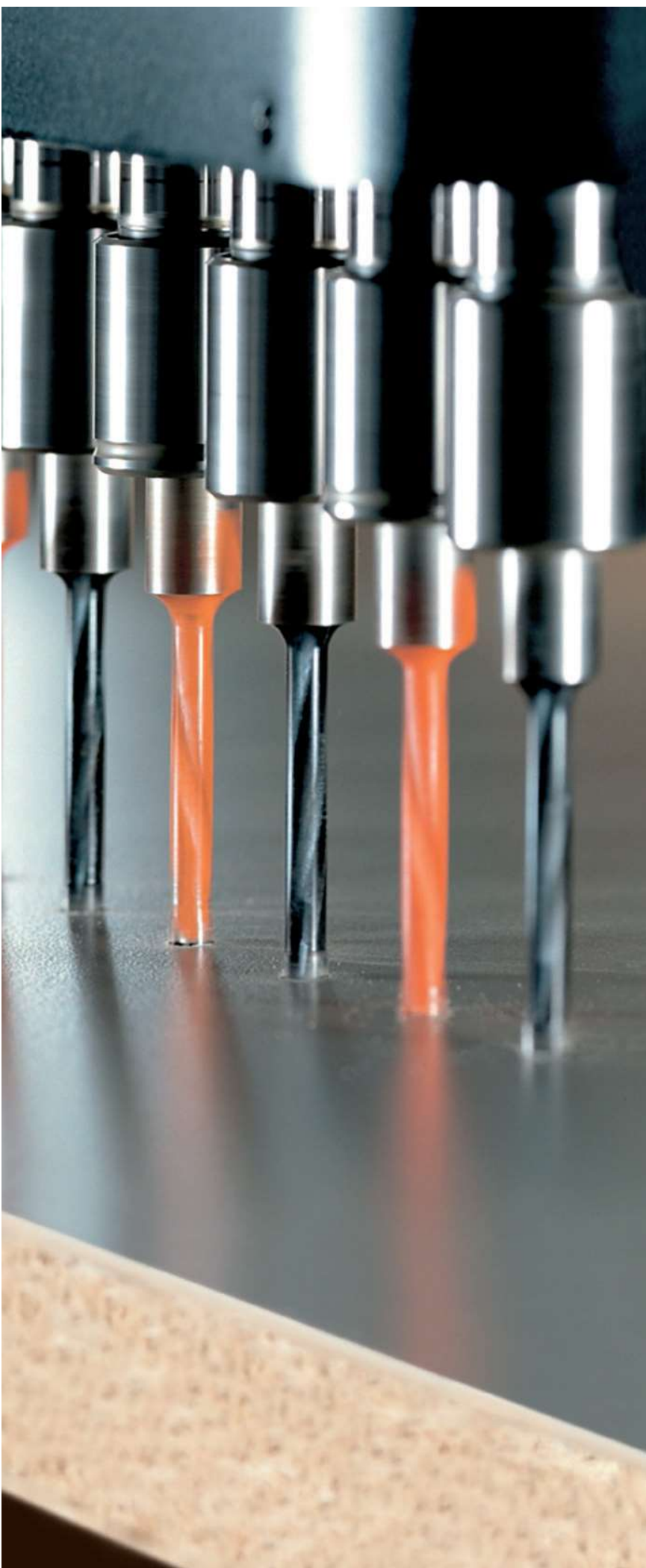

PRODUCTS	PAGE
Adapters	292~294
XTreme Solid Carbide Boring Bits	295~297
XTreme Boring Bits	298-299
Solid Carbide Twist Drills	300-301
2 Flute Dowel Drills	302-303
4 Flute Dowel Drills	304~306
Dowel Drills with Countersink	307
Through Hole Dowel Drills	308-309
Countersinks	310
Hinge Boring Bits	311~313
Dowel Drills with Threaded Shank	314~316



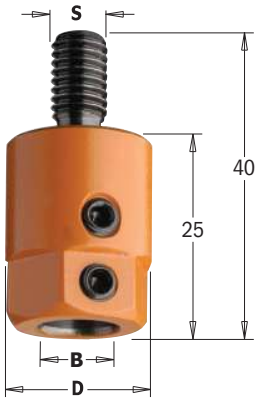

301

RH LH

B mm	D mm	S mm		ORDER NO. Right-hand rotation	ORDER NO. Left-hand rotation
8	16	M8	10	301.080.01	301.080.02
10	19,5	M8	10	301.000.01	301.000.02

FOR USE ON THE FOLLOWING MACHINES:
Nottmeyer (older models).

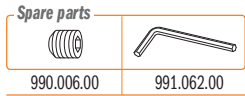

302

RH LH

B mm	D mm	S mm		ORDER NO. Right-hand rotation	ORDER NO. Left-hand rotation
8	16	M10	10	302.080.01	302.080.02
10	19,5	M10	10	302.000.01	302.000.02

FOR USE ON THE FOLLOWING MACHINES:
Ayen, Holzma, Knoevenagel, Mayer, Torwegge.

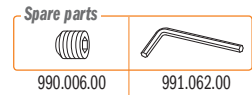

303

RH LH

B mm	D mm	S mm		ORDER NO. Right-hand rotation	ORDER NO. Left-hand rotation
8	16	M10/30°	10	303.080.01	303.080.02
10	19,5	M10/30°	10	303.000.01	303.000.02

FOR USE ON THE FOLLOWING MACHINES:
Alberti (older models).
Balestrini, Bilek, Busellato (older models).
Schleicher, Vitap (older models).

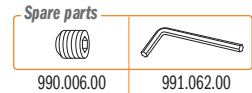

304

RH LH

B mm	D mm	S mm		ORDER NO. Right-hand rotation	ORDER NO. Left-hand rotation
8	16	M8/20° 48'	10	304.080.01	304.080.02
10	19,5	M8/20° 48'	10	304.000.01	304.000.02

FOR USE ON THE FOLLOWING MACHINES:
Balestrini, Bilek.

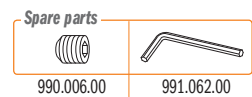

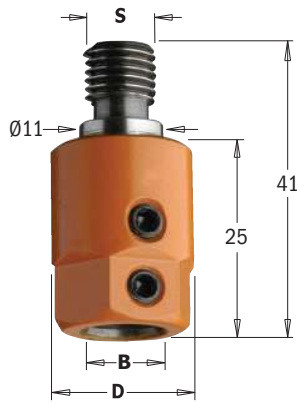

305

RH LH

B mm	D mm	S mm		ORDER NO. Right-hand rotation	ORDER NO. Left-hand rotation
8	16	M10/11		305.080.01	305.080.02
10	19,5	M10/11		305.000.01	305.000.02

FOR USE ON THE FOLLOWING MACHINES:
 Biesse (older models).
 Masterwood (Zangheri & Boschetti).
 Morbidelli, Torwegge, Vitap (new design).
 Weeke.

Spare parts

990.006.00	991.062.00

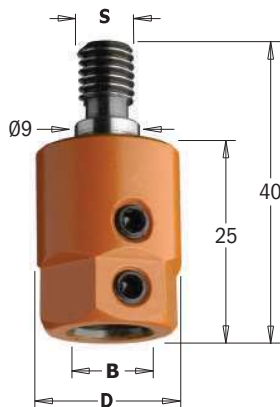

358

RH LH

B mm	D mm	S mm		ORDER NO. Right-hand rotation	ORDER NO. Left-hand rotation
8	16	M8/9		358.080.01	358.080.02
10	19,5	M8/9		358.000.01	358.000.02

FOR USE ON THE FOLLOWING MACHINES:
 Masterwood (Zangheri & Boschetti).
 Morbidelli, Nottmeyer (new design).

Spare parts

990.006.00	991.062.00



359

RH LH

B mm	D mm	S mm		ORDER NO. Right-hand rotation	ORDER NO. Left-hand rotation
10	19,5	M10		359.000.01	359.000.02

FOR USE ON THE FOLLOWING MACHINES:
 Scheer.

Spare parts

990.006.00	991.062.00



360.001

RH LH

B mm	d mm	D mm		ORDER NO. Right-hand rotation	ORDER NO. Left-hand rotation
10	20	15		360.001.01	360.001.02

FOR USE ON THE FOLLOWING MACHINES:
 For Biesse machines with quick drill change attachment.

Spare parts

990.007.00	991.067.00