

TOOLS WITH BORE & KNIVES



PRODUCTS	PAGE
Rabbeting Cutter Heads	96-97
Adjustable Grooving Set	98-99
Planing & Jointing Spiral Cutter Heads	100
2 piece Adjustable Rounding & Chamfering Set	101
Chamfer Cutter Heads	102-103
Multiradius Roundover Cutter Heads	104-106
Jointing Cutter Heads	107-109
Panel Cutter Heads	110-114
Cutter Heads for Universal Knives & Sets	115-117
Profile Knives & Limiters	118-131
Blank Knives & Limiters (to be sharpened)	132
Bore Reducers	132
HS Corrugated Back Moulder Knives	133
Magnetic Knife Setting Jigs	133
Planer & Joints Knives	134-135
HWM Reversible Knives	136-137
HWM Reversible Knives for Portable Planers	138



Rabbeting Cutter Heads



694.100



These cutter heads have been designed for:

- rabbeting from either top or bottom;
- jointing
- grooving

For use on spindle moulder machines, double-end tenoner and edging machines.

Suitable for all materials, but best on chipboard, MDF, wood composites, plastic materials and laminates. Improved design with shear angle.

TECHNICAL DETAILS:

- Hard aluminium alloy body with high resistance to tensile and yield stress.
- 2 universal HWM straight knives 50x12x1,5mm [Z2], 1 up cut - 1 down cut.
- 4 universal HWM scoring knives 14x14x2mm [V4].
- Tools for manual feed (MAN).
- Pins for automatic positioning of the knives.

Supplied in a solid plastic box.

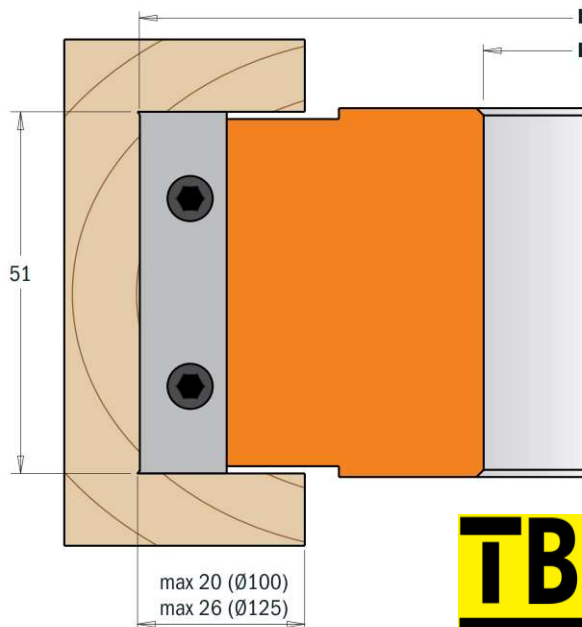
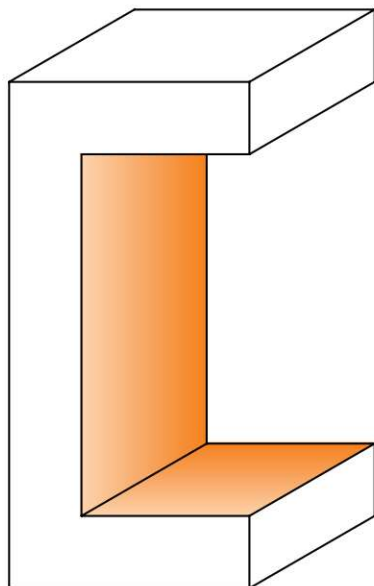
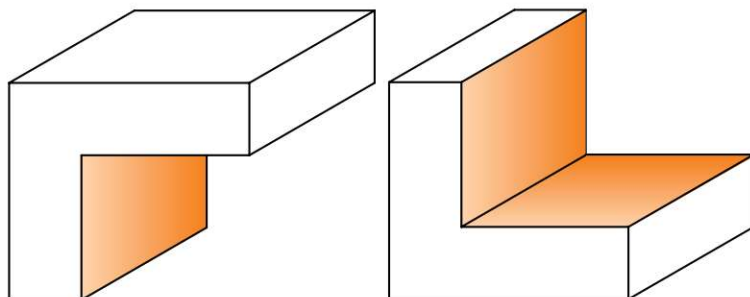

Drawing is 1:1 scale



D mm	B mm	I mm	Z+V	RPM		ORDER NO.	Spare parts							
100	19,05	51	2+4	7500~12500	1	694.100.19								
100	30	51	2+4	7500~12500	1	694.100.30	790.140.00	990.093.00	991.073.00	790.500.00	695.999.46	990.064.00	991.064.00	
100	31,75	51	2+4	7500~12500	1	694.100.31	790.140.00	990.093.00	991.073.00	790.500.00	695.999.46	990.064.00	991.064.00	
100	35	51	2+4	7500~12500	1	694.100.35	790.140.00	990.093.00	991.073.00	790.500.00	695.999.46	990.064.00	991.064.00	
125	40	51	2+4	6100~10000	1	694.125.40	790.140.00	990.093.00	991.073.00	790.500.00	695.999.46	990.064.00	991.064.00	
125	50	51	2+4	6100~10000	1	694.125.50	790.140.00	990.093.00	991.073.00	790.500.00	695.999.46	990.064.00	991.064.00	

790.140.00 and 790.500.00 are supplied in 10-piece pack or multiple

Cutter Heads for Rabbeting with 40mm Profile Knives



694.020

These cutter heads have been designed for:

- rabbeting from either top or bottom;
- jointing
- grooving
- 40mm SP profile knives

For use on spindle moulder machines, double-end tenoners and edging machines.

Suitable for all materials, but best on chipboard, MDF, wood composites, plastic materials and laminates.

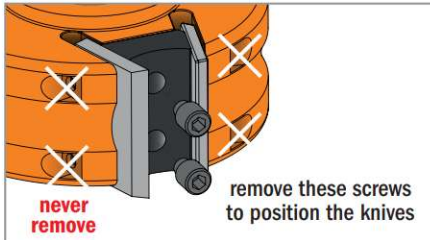

TECHNICAL DETAILS:

- Hard aluminium alloy body with high resistance to tensile and yield stress.
- 2 universal HWM straight knives 40x12x1,5mm [Z2].
- 2 universal HWM scoring knives 14x14x2mm [V2].
- Tools for manual feed (MAN).
- Pins for the automatic positioning of the knives.

Supplied in a solid plastic box.

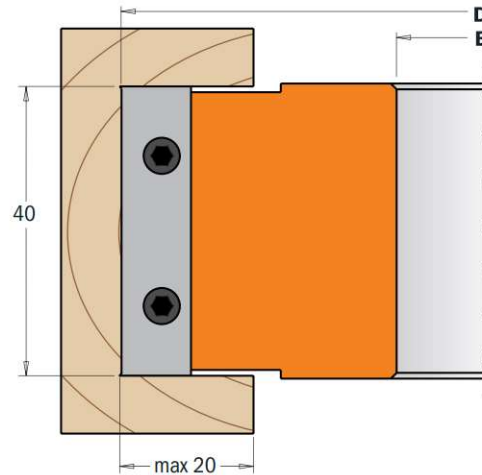
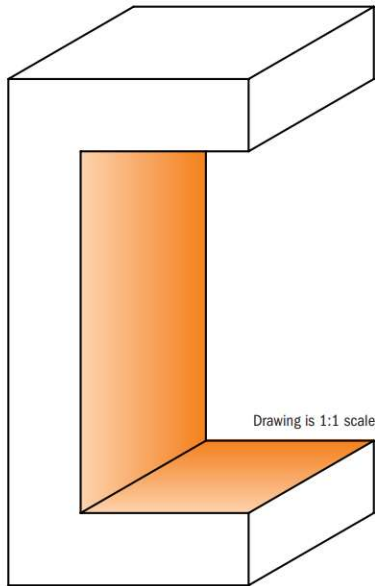

To use with all 40mm profile knives
(refer to pages 118 to 127)

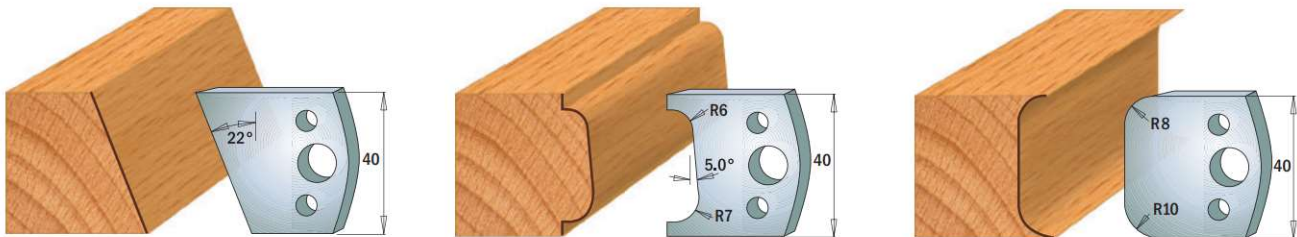

D mm	B mm	I mm	Z+V	RPM	Box	ORDER NO.	Spare parts						
100	30	40	2+2	7500~12500	1	694.020.30							
100	31,75	40	2+2	7500~12500	1	694.020.31	790.140.00	990.093.00	991.073.00	790.400.00	693.999.01	990.065.00	991.064.00
125	35	40	2+2	7500~12500	1	694.020.35	790.140.00	990.093.00	991.073.00	790.400.00	693.999.01	990.065.00	991.064.00
125	40	40	2+2	7500~12500	1	694.020.40	790.140.00	990.093.00	991.073.00	790.400.00	693.999.01	990.065.00	991.064.00
125	50	40	2+2	7500~12500	1	694.020.50	790.140.00	990.093.00	991.073.00	790.400.00	693.999.01	990.065.00	991.064.00

Spare parts
691.192 Pair of limiters 40x4mm
695.020.01 Indexable knife edge block 38x4x15mm

790.140.00 and 790.400.00 are supplied in 10-piece pack or multiple



3 piece Adjustable Grooving Sets



Darbagaldi & Instrumenti



694.001

These cutter heads are the ideal tools to create precision slots and grooves on material 4 to 15mm deep.

- These sets include:
- 2 cutter heads type (A) [Z4 + V4]
 - 1 cutter head type (B) [Z2]
 - 12 spacer rings from 0,1 to 2mm

For use on your spindle moulder machines, double-end tenoner and shaper machines.
Perfect grooving on all materials, but ideal on solid wood, plywood and laminated panels.

TECHNICAL DETAILS:

- Super-strength steel body.
- 2 HWM Knives 7,65x12x1,5mm [Z2].
- 4 HWM Knives 18x18x1,95mm [Z4].
- 4 HWM Knives 14x14x1,2mm [V4].
- Tools for manual feed (MAN).
- Pins for automatic positioning of the knives.

Supplied in a solid plastic box.

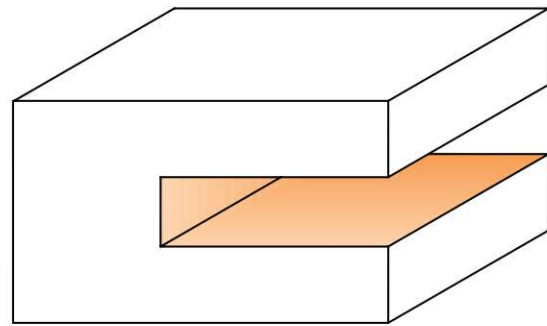
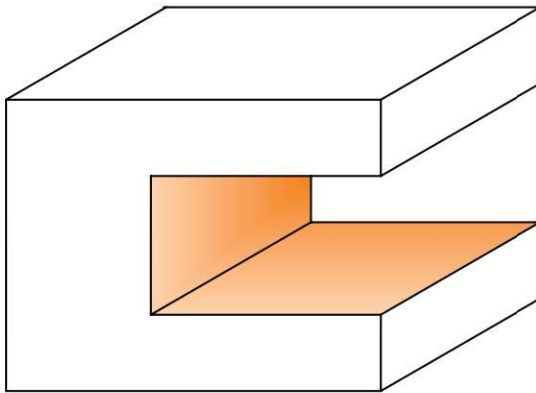
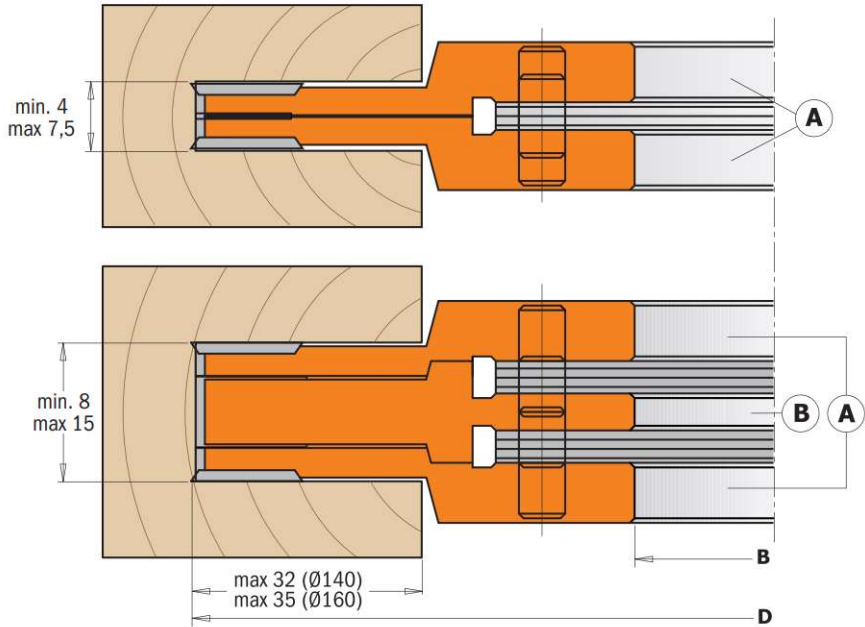

Drawing is 1:1 scale

D mm	B mm	Z+V	RPM		ORDER NO.				
140	30	4+4	5500~9500	1	694.001.30	790.181.00	790.140.10	790.076.00	695.998.21
140	31,75	4+4	5500~9500	1	694.001.31	790.181.00	790.140.10	790.076.00	695.998.22
140	35	4+4	5500~9500	1	694.001.35	790.181.00	790.140.10	790.076.00	695.998.23
160	40	4+4	4800~8300	1	694.001.40	790.181.00	790.140.10	790.076.00	695.998.24N
160	50	4+4	4800~8300	1	694.001.50	790.181.00	790.140.10	790.076.00	695.998.25N

Spare parts For cutter heads (A)

- 990.079.00 M4x3,2mm Torx screws
- 991.069.00 T9 Torx key
- 695.996.02 M4 (Ø12x1,7mm) threaded ring
- 695.996.01 M4 (Ø10x1,6mm) threaded ring

Spare parts For cutter heads (B)

- 695.999.07 7x11x9,5mm wedge for knives
- 990.063.00 M5x18mm screw
- 991.072.00 T20 Torx key

790.181.00, 790.140.10 and 790.076.00 are supplied in 10-piece pack or multiple

2 Piece Adjustable Grooving Sets



694.021 - 694.022



These cutter heads are the ideal tools to create precision slots and grooves on material from 14 to 39mm deep. These sets include:
 - 1 cutter head type (A) [Z2 + V2]
 - 1 cutter head type (B) [Z2 + V2]
 - spacer rings set

For use on spindle moulder machines, double-end tenoners and shaper machines. Perfect grooving on all materials, but ideal on solid wood, plywood and laminated panels.

TECHNICAL DETAILS:

- Super-strength hard aluminium alloy body.
- **694.021:** 8 HWM knives 13,6x13,6x2mm.
- **694.022:** 4 HWM knives 19,5x12x1,5mm.
4 HWM knives 14x14x2mm.
- Tools for manual feed (MAN).
- Pins for the automatic positioning of the knives.



299 Spacer Rings (Optional)

ORDER NO.	B mm	D mm	P mm
299.560.30	30	60	5
299.560.31	31,75	60	5
299.560.35	35	60	5
299.560.40	40	60	5
299.560.50	50	70	5

Ring for thickness above 14mm (9/16")

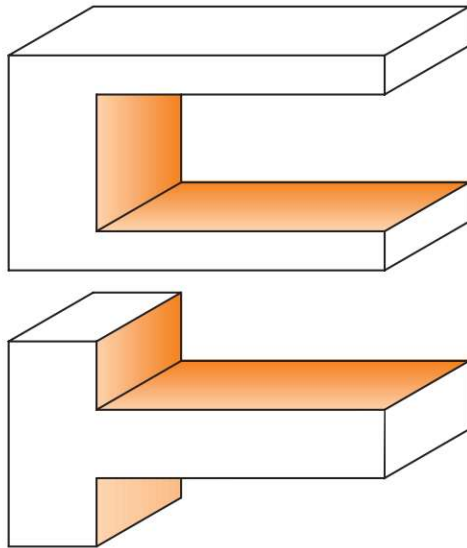
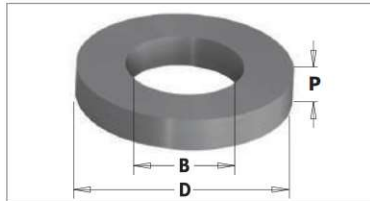

Drawing is 1:1 scale

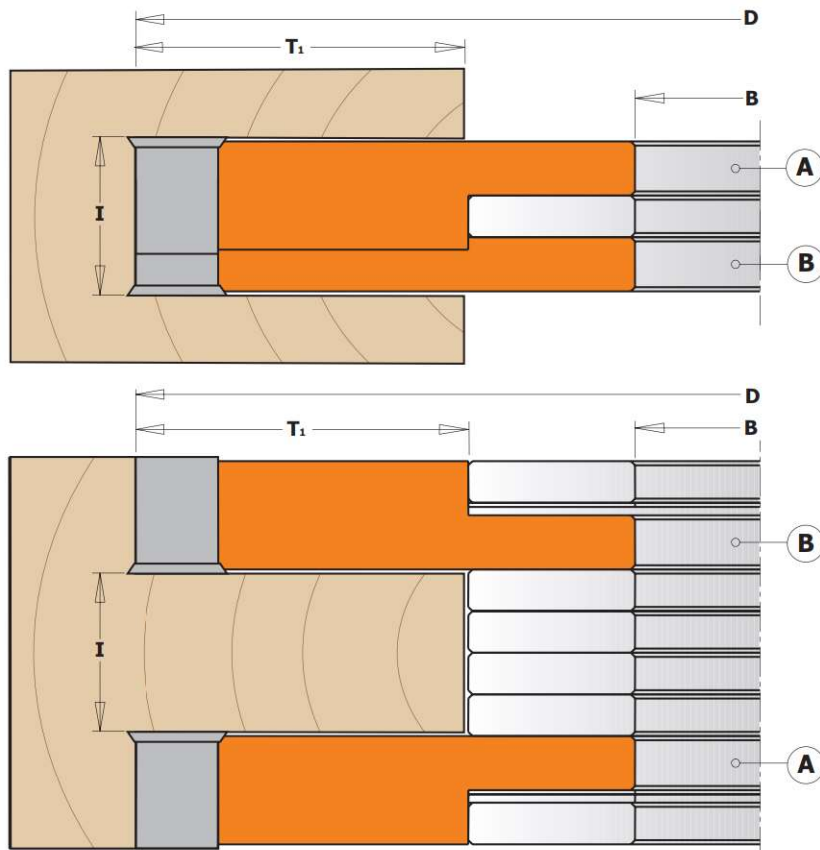

D mm	I mm	B mm	T ₁ mm	Z+V	RPM		ORDER NO.	Spare parts									
150	14-27	30	44	4+4	5000~8000	1	694.021.30						790.136.00	990.093.00			695.998.41
150	14-27	31,75	44	4+4	5000~8000	1	694.021.31	790.136.00	990.093.00								695.998.42
150	14-27	35	44	4+4	5000~8000	1	694.021.35	790.136.00	990.093.00								695.998.43
150	14-27	40	44	4+4	5000~8000	1	694.021.40	790.136.00	990.093.00								695.998.44
160	14-27	50	44	4+4	5000~8000	1	694.021.50	790.136.00	990.093.00								695.998.45
170	20-39	30	54	4+4	4400~7400	1	694.022.30	790.140.00	990.093.00	790.195.12	990.094.00		695.998.46				
170	20-39	31,75	54	4+4	4400~7400	1	694.022.31	790.140.00	990.093.00	790.195.12	990.094.00		695.998.47				
170	20-39	35	54	4+4	4400~7400	1	694.022.35	790.140.00	990.093.00	790.195.12	990.094.00		695.998.48				
170	20-39	40	54	4+4	4400~7400	1	694.022.40	790.140.00	990.093.00	790.195.12	990.094.00		695.998.49				
170	20-39	50	49	4+4	4400~7400	1	694.022.50	790.140.00	990.093.00	790.195.12	990.094.00		695.998.50				

Spare parts
 991.072.00 T20 Torx key
 991.073.00 T25 Torx key

790.136.00, 790.140.00 and 790.195.12 are supplied in 10-piece pack or multiple

Planing & Jointing Spiral Cutter Heads

Darbagaldi & Instrumenti



694.019

These new cutter heads have been designed for planing and jointing on soft or hard wood and wooden boards on spindle moulder machines. Ideal for routing curved elements with the aid of a bearing guide (sold separately) and a template.

TECHNICAL DETAILS:

- Hard aluminium alloy body with high resistance to tensile and yield stress.
- 12 HWM Knives 14x14x2mm [Z2] with 4 spiral indexing.
- Tools for manual feed (MAN).

Supplied in a plastic twistpack.

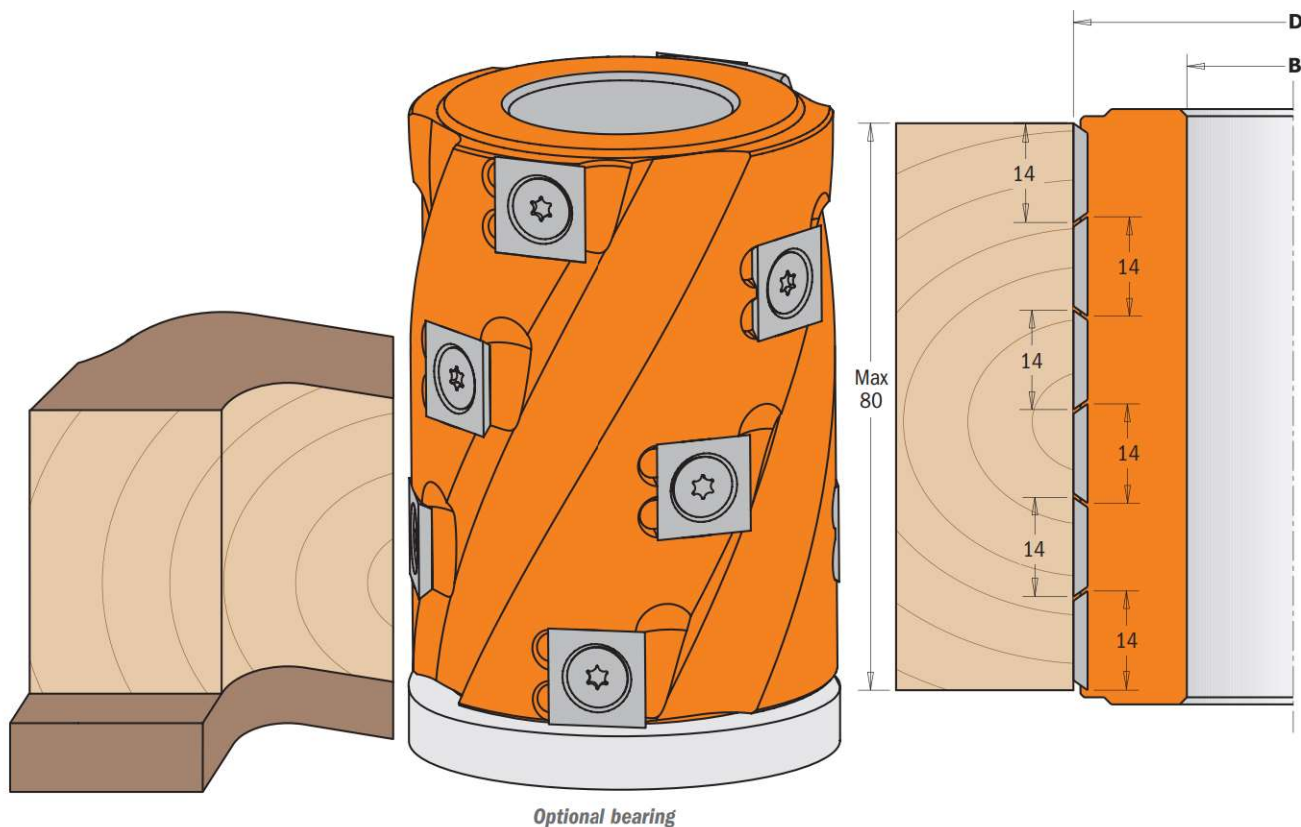

D mm	I mm	B mm	Z	RPM		ORDER NO.	Spare parts		
62	80	30	12	8000~12000	1	694.019.30			
62	80	35	12	8000~12000	1	694.019.35	790.140.00	990.093.00	991.073.00
80	80	40	12	8000~12000	1	694.019.40	790.140.00	990.093.00	991.073.00
80	80	50	12	8000~12000	1	694.019.50	790.140.00	990.093.00	991.073.00

Optional

791.051.00	30x62x16mm bearing
791.052.00	35x62x14mm bearing
791.054.00	40x80x18mm bearing
791.053.00	50x80x16mm bearing

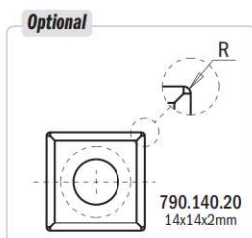

NOTE: In order to achieve an extra-fine finish, you can order the optional knife 790.140.20

790.140.00 and 790.140.20 are supplied in 10-piece pack or multiple

2 Piece Adjustable Rounding & Chamfering Sets



694.005



Innovative design, simple assembly and countless possibilities. The CMT adjustable rounding and chamfering sets consist of two pieces, which are very easy to set up on your spindle moulder machine, allowing you to profile on solid wood and synthetic boards (with or without coating). Includes five different knives for rounding over top and bottom edges in one single pass with a radius of 2,3,4,5 or 6mm and for 45° chamfering on material 18mm to 50mm in thickness.

The improved design with shear angle guarantees perfect finishing! For use on spindle moulder machines and double-end tenoners.

TECHNICAL DETAILS:

- Hard aluminium alloy body with high resistance to tensile and yield stress.
- One pair of HWM top knives radius 4mm and 45° chamfer (20x20,5x2mm) [Z2].
- One pair of HWM bottom knives radius 4mm and 45° chamfer (20x20,5x2mm) [Z2].
- Two HWM knives 50x12x1,5mm.
- Set of 21 spacer rings from 0,1 to 3mm.
- Tools for manual feed (MAN).
- Pins for the automatic positioning of the knives.

Supplied in a solid plastic box.

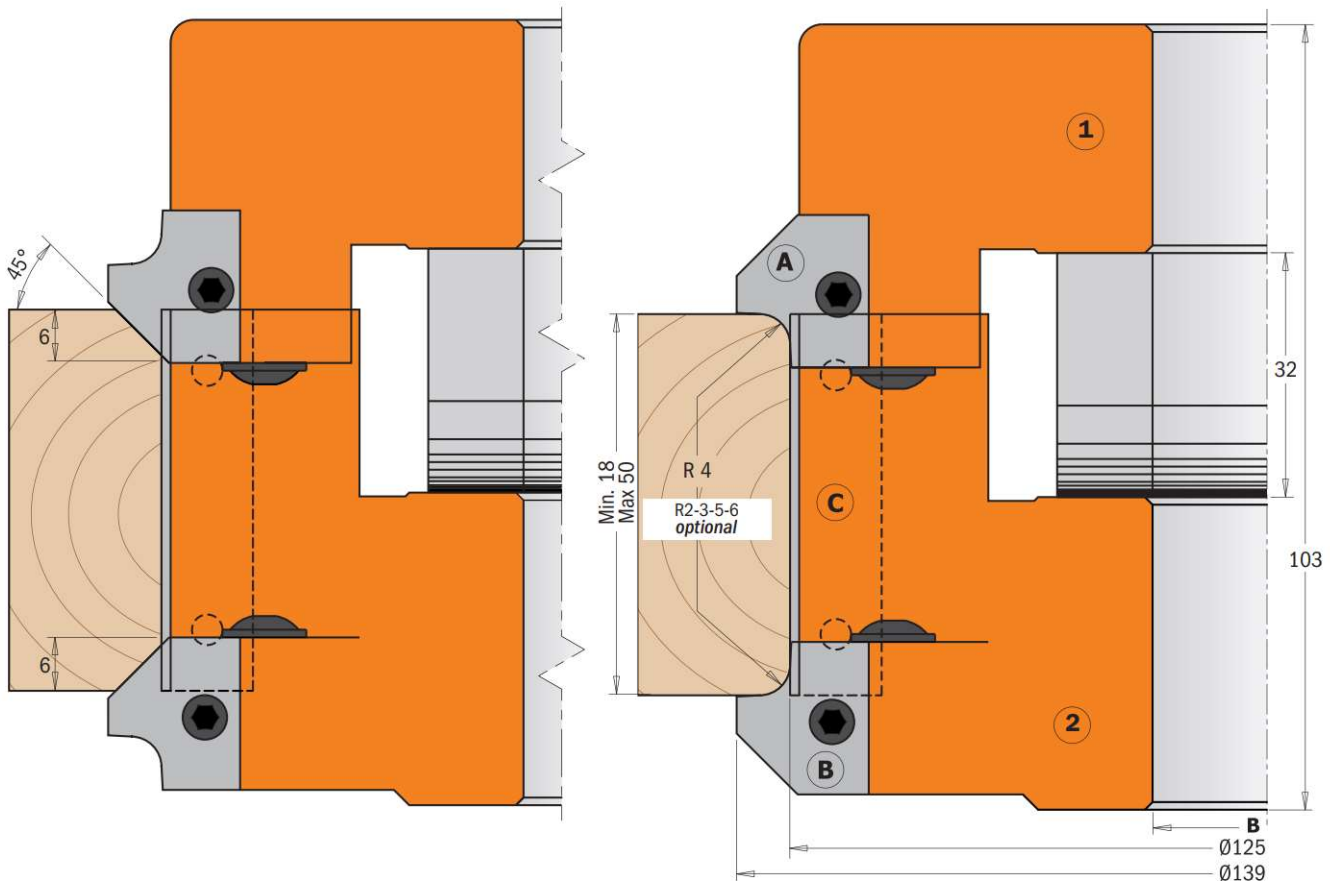

D mm	B mm	Z	RPM	Box	ORDER NO.	Spare parts			
139	30	2+2	5500~9400	1	694.005.30	17x11x9,5mm 695.999.17	46x11x9,5mm 695.999.46	990.064.00	695.998.11
139	31,75	2+2	5500~9400	1	694.005.31	695.999.17	695.999.46	990.064.00	695.998.12
139	35	2+2	5500~9400	1	694.005.35	695.999.17	695.999.46	990.064.00	695.998.13
139	40	2+2	5500~9400	1	694.005.40	695.999.17	695.999.46	990.064.00	695.998.14
139	50	2+2	5500~9400	1	694.005.50	695.999.17	695.999.46	990.064.00	695.998.15

Spare parts

695.005.A4	R=4+45° pair of knives for roundover/chamfer (top)
695.005.B4	R=4+45° pair of knives for roundover/chamfer (bottom)
790.500.00	50x12x1,5mm knives
991.064.00	4mm hex key
991.067.00	3mm hex key

Optional

695.005.A2	R=2+45° pair of knives for roundover/chamfer (top)
695.005.A3	R=3+45° pair of knives for roundover/chamfer (top)
695.005.A5	R=5+45° pair of knives for roundover/chamfer (top)
695.005.A6	R=6+45° pair of knives for roundover/chamfer (top)
695.005.B2	R=2+45° pair of knives for roundover/chamfer (bottom)
695.005.B3	R=3+45° pair of knives for roundover/chamfer (bottom)
695.005.B5	R=5+45° pair of knives for roundover/chamfer (bottom)
695.005.B6	R=6+45° pair of knives for roundover/chamfer (bottom)

45° Chamfer Cutter Heads



Darbagaldi & Instrumenti



694.002

CMT chamfer cutter heads carry out clean accurate bevells and joints for excellent edge work. For use on spindle moulder machines, double-end tenoner and shaper machines. Suitable for all materials, but ideal on solid wood, veneer, plywood and laminated materials.

TECHNICAL DETAILS:

- Hard aluminium alloy body with high resistance to tensile and yield stress.
- 2 HWM Knives 50x12x1,5mm [Z2].
- Tools for manual feed (MAN).
- Pins for the automatic positioning of the knives.

Supplied in a solid plastic box.

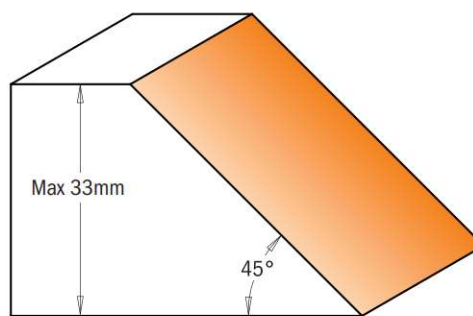
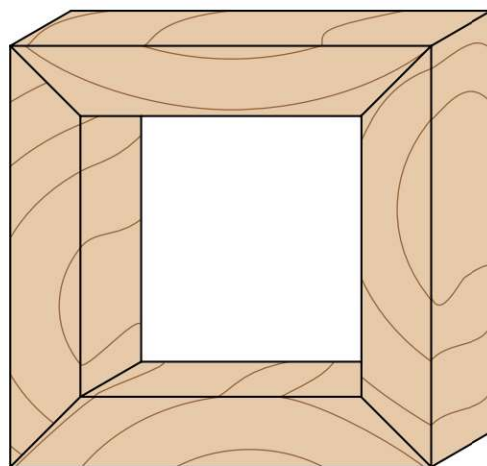
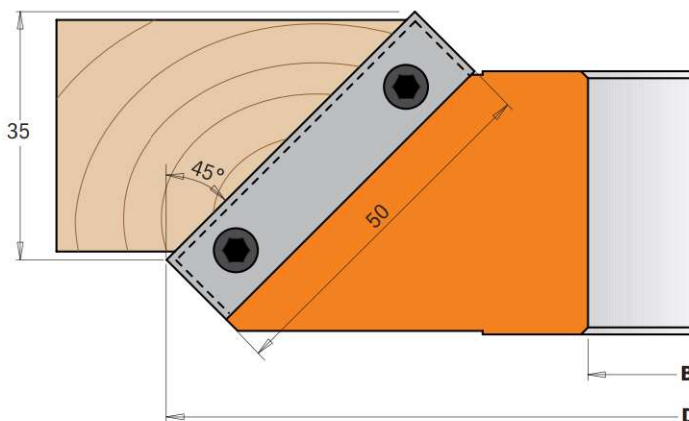

Drawing is 1:1 scale

D mm	B mm	Z	RPM		ORDER NO.
150	30	2	5100-8800	1	694.002.30
150	31,75	2	5100-8800	1	694.002.31
150	35	2	5100-8800	1	694.002.35
150	40	2	5100-8800	1	694.002.40
160	50	2	4800-8300	1	694.002.50

Spare parts

790.500.00	695.999.42	990.064.00	991.064.00
790.500.00	695.999.42	990.064.00	991.064.00
790.500.00	695.999.42	990.064.00	991.064.00
790.500.00	695.999.42	990.064.00	991.064.00
790.500.00	695.999.42	990.064.00	991.064.00

790.500.00 are supplied in 10-piece pack or multiple

Adjustable Chamfer Cutter Heads with Positive Stop

TBOX **CMT ORANGE TOOLS**

694.018

Darbagaldi & Instrumenti



This chamfer cutter head carries out very precise cuts on wooden boards and solid timber. It also crafts gap-free bevel joints and is the perfect tool for a variety of joinery projects. For use on spindle moulding machines, double-end tenoners and shaper machines.

TECHNICAL DETAILS:

- Tool body made from high strength aluminum alloy extremely resistant to tensile and yield stress
- Manual feed tool (MAN)
- 2 HWM knives 40x12x1,5mm[Z2]
- Adjustable swivelling blades
- Range: $\pm 45^\circ$ (Rotates at $7,5^\circ$ intervals; Precision= $7,5^\circ$)

Supplied in a solid plastic box.

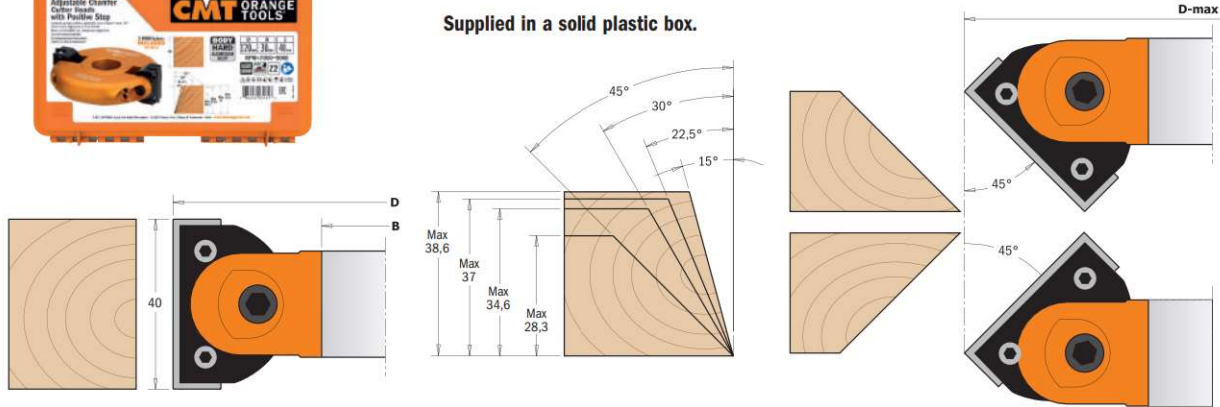

D mm	I mm	B mm	Z	D_Max 45° mm	RPM		ORDER NO.
120	40	30	2	140	7000~9000	1	694.018.30
120	40	35	2	140	7000~9000	1	694.018.35
145	40	40	2	165	4800~7200	1	694.018.40
145	40	50	2	165	4800~7200	1	694.018.50

Spare parts

695.018.01	790.400.00	990.094.00	991.072.00
695.018.01	790.400.00	990.094.00	991.072.00
695.018.01	790.400.00	990.094.00	991.072.00
695.018.01	790.400.00	990.094.00	991.072.00

Spare parts 991.065.00 5mm hex key

790.400.00 are supplied in 10-piece pack or multiple

Professional Adjustable Chamfer Cutter Heads with Gear Box

694.017

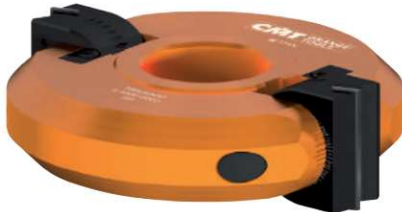

These new professional adjustable chamfer cutter heads carry out precise cuts, accurate bevels and joints on wooden boards and solid timber. For use on spindle moulder machines, double-end tenoner and shaper machines.

TECHNICAL DETAILS:

- Tool body made from high strength aluminum alloy extremely resistant to tensile and yield stress
- Manual feed tool (MAN)
- 2 HWM knives 50x12x1,5mm [Z2]
- Adjustable swivelling blades
- Range $\pm 90^\circ$ (Rotates at $7,5^\circ$ intervals; Precision = $7,5^\circ$)

Supplied in a solid plastic box.

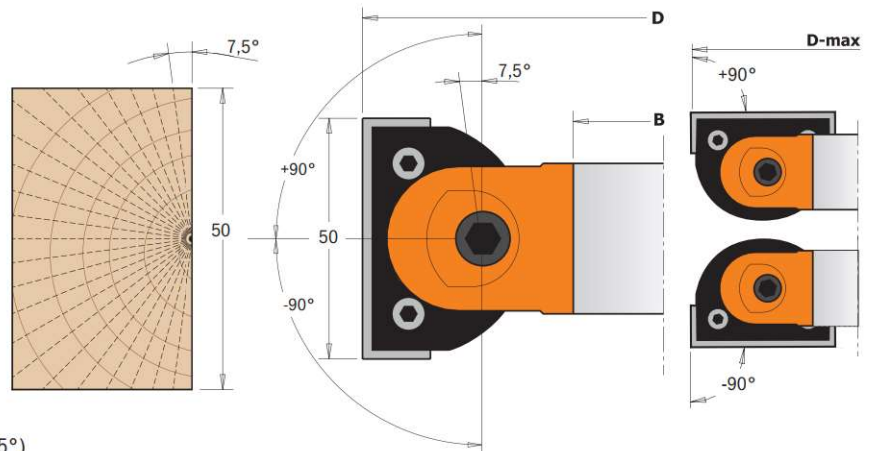

D mm	I mm	B mm	Z	D_Max 45° mm	RPM		ORDER NO.
160	50	30	2	183	4800~6000	1	694.017.30
160	50	35	2	183	4800~6000	1	694.017.35
160	50	50	2	183	4800~6000	1	694.017.50

Spare parts

695.017.01	790.500.00	695.999.48	990.106.00	991.067.00
695.017.01	790.500.00	695.999.48	990.106.00	991.067.00
695.017.01	790.500.00	695.999.48	990.106.00	991.067.00

Spare parts 991.081.00 4mm hex key

790.500.00 are supplied in 10-piece pack or multiple

Multiradius Roundover Cutter Heads



694.003

Darbagaldi & Instrumenti



Innovative cutter heads supporting three different knives for making six radius roundover profiles. Standard cutter heads are sold with knives featuring 5 and 10mm radii; two more knife sets are available for radii 4-8mm and 3-6mm. For use on spindle moulder machines, double-end tenoner and shaper machines. Suitable for all materials, but ideal on solid wood and panel materials.

TECHNICAL DETAILS:

- Hard aluminium alloy body with high resistance to tensile and yield stress.
- 2 HWM knives radius 5/10mm (25x24,8x2mm) [Z2].
- Tools for manual feed (MAN).
- Pins for the automatic positioning of the knives.

Supplied in a solid plastic box.

Standard

Pair of knives **695.003.05**

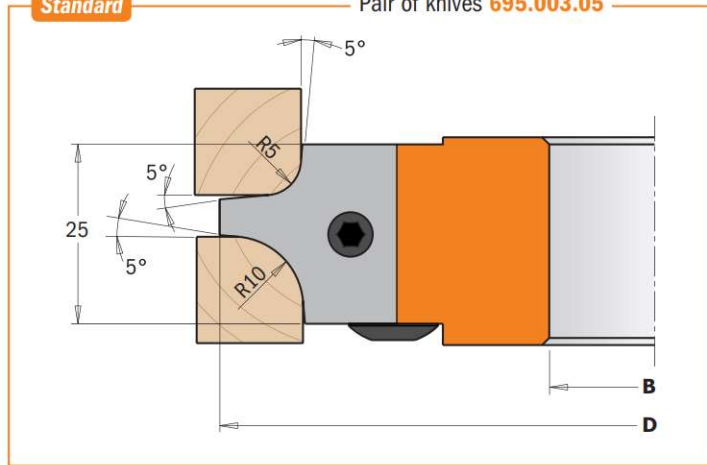

Optional

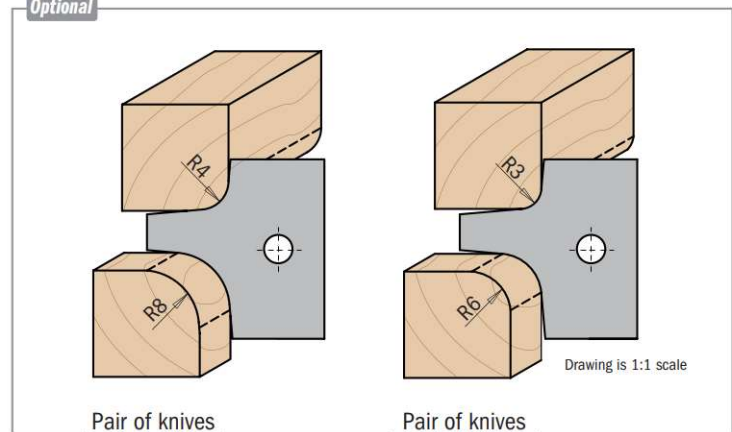

Pair of knives **695.003.04**

Pair of knives **695.003.03**

D mm	B mm	Z	RPM		ORDER NO.	Spare parts			
113	30	2	6700~11000	1	694.003.30	x2			
113	31,75	2	6700~11000	1	694.003.31	695.003.05	695.999.22	990.064.00	991.064.00
113	35	2	6700~11000	1	694.003.35	695.003.05	695.999.22	990.064.00	991.064.00
128	40	2	5900~9700	1	694.003.40	695.003.05	695.999.22	990.064.00	991.064.00
128	50	2	5900~9700	1	694.003.50	695.003.05	695.999.22	990.064.00	991.064.00

Optional
 695.003.04 R=4/8mm (25x24,8x2mm) pair of profiled knives
 695.003.03 R=3/6mm (25x24,8x2mm) pair of profiled knives

Multiradius Roundover Cutter Heads



Darbagaldi & Instrumenti



694.004

Innovative cutter heads supporting two different knives for making four radius roundover profiles. Standard cutter heads are sold with knives featuring radii 15 and 20mm; one more knife set is available for radii 12-18mm. For use on spindle moulder machines, double-end tenoner and shaper machines. Suitable for all materials, but ideal on solid wood and panel materials.

TECHNICAL DETAILS:

- Hard aluminium alloy body with high resistance to tensile and yield stress.
- 2 HWM knives radius 15/20mm (45x34,5x2mm) [Z2].
- Tools for manual feed (MAN).
- Pins for the automatic positioning of the knives.

Supplied in a solid plastic box.

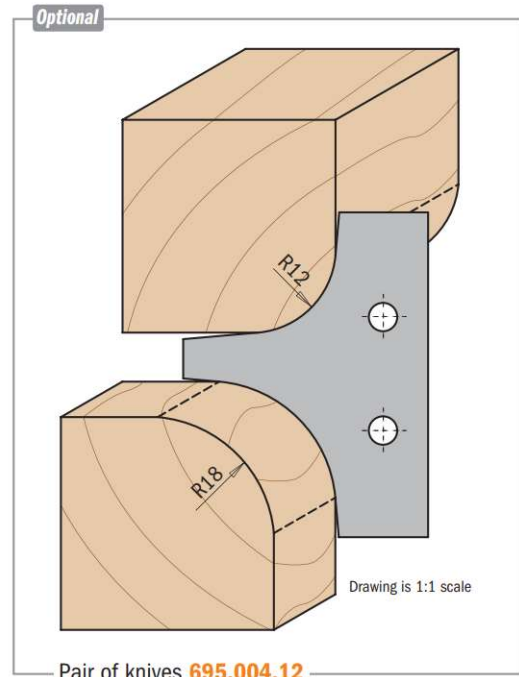
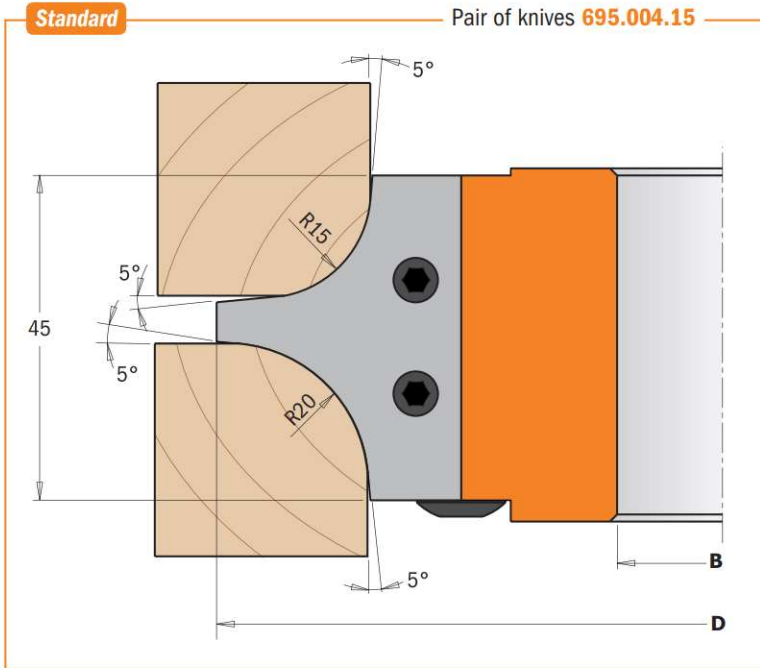

D mm	B mm	Z	RPM		ORDER NO.
132	30	2	5700-9500	1	694.004.30
132	31,75	2	5700-9500	1	694.004.31
132	35	2	5700-9500	1	694.004.35
147	40	2	5100-8500	1	694.004.40
147	50	2	5100-8500	1	694.004.50

Spare parts

695.004.15 x2	695.999.42	990.064.00	991.064.00
695.004.15	695.999.42	990.064.00	991.064.00
695.004.15	695.999.42	990.064.00	991.064.00
695.004.15	695.999.42	990.064.00	991.064.00
695.004.15	695.999.42	990.064.00	991.064.00

Optional 695.004.12 R=12/18mm (45x34,5x2mm) pair of profiled knives

Roundover & Cove Cutter Heads



Darbagaldi & Instrumenti



694.007

These cutter heads are perfect for making furniture, doors and drawer fronts simply and stylishly by giving them a final touch with a CMT cove bit. It is also used for making perfect roundover profiles, drop leaf counters and table tops. You can use three different knives for carrying out roundover and cove profiles with radius 10, 12 and 15mm. For use on spindle moulder machines, double-end tenoner and shaper machines. Suitable for all materials, but ideal on solid wood and panel materials.

TECHNICAL DETAILS:

- Hard aluminium alloy body with high resistance to tensile and yield stress.
- 2 HWM knives radius 10mm (34,8x29,3x2mm) [Z2].
- Tools for manual feed (MAN).
- Pins for the automatic positioning of the knives.

Supplied in a solid plastic box.

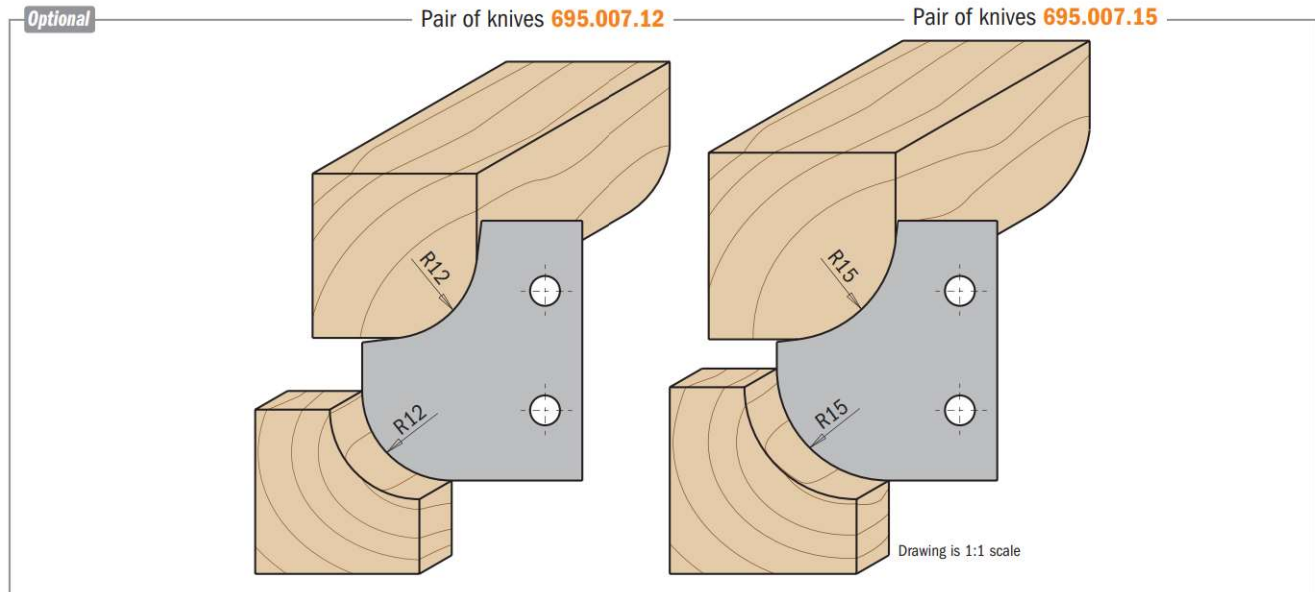
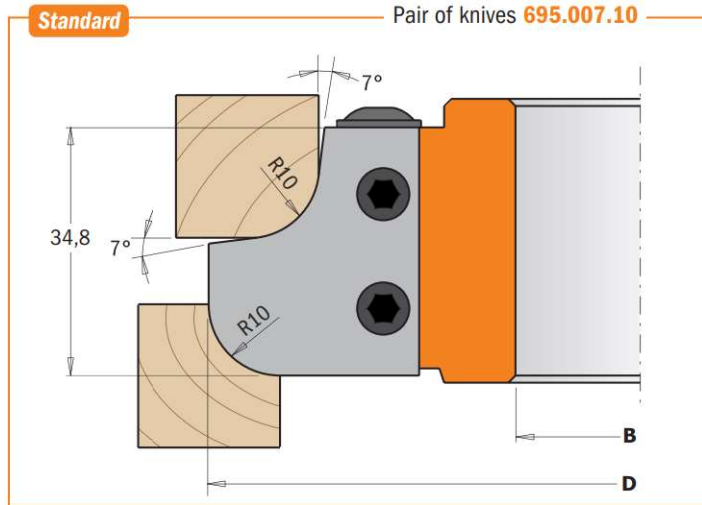

D mm	B mm	Z	RPM		ORDER NO.	Spare parts			
121	30	2	6300~10500	1	694.007.30	x2			
121	31,75	2	6300~10500	1	694.007.31	695.007.10	695.999.31	990.064.00	991.064.00
121	35	2	6300~10500	1	694.007.35	695.007.10	695.999.31	990.064.00	991.064.00
136	40	2	5600~9300	1	694.007.40	695.007.10	695.999.31	990.064.00	991.064.00
136	50	2	5600~9300	1	694.007.50	695.007.10	695.999.31	990.064.00	991.064.00

Optional
 695.007.12 R=12mm (34,8x29,3x2mm) pair of roundover/cove knives
 695.007.15 R=15mm (34,8x29,3x2mm) pair of roundover/cove knives

Professional Finger Joint Cutter Heads

TBOX

CMT ORANGE TOOLS

694.008

Darbagaldi & Instrumenti

INSERT CARBIDE

MAN

Z2



The CMT professional finger joint cutter head makes the strongest side-to-side joints on all wood types and composites. The tightness of the joint and the maximum surface area for glue application ensure that the joint itself is stronger than an unworked piece of wood. Maximum thickness 47mm. For use on spindle moulder machines, double-end tenoner and shaper machines. Suitable for all materials, but ideal on solid wood and panel materials.

TECHNICAL DETAILS:

- Hard aluminium alloy body with high resistance to tensile and yield stress.
- 2 HWM knives 49,6x11,9x1,5mm [Z2].
- Tools for manual feed (MAN).
- Pins for the automatic positioning of the knives.

Supplied in a solid plastic box.

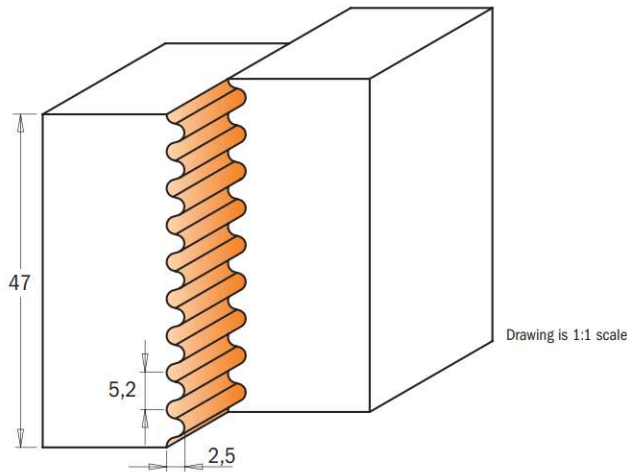
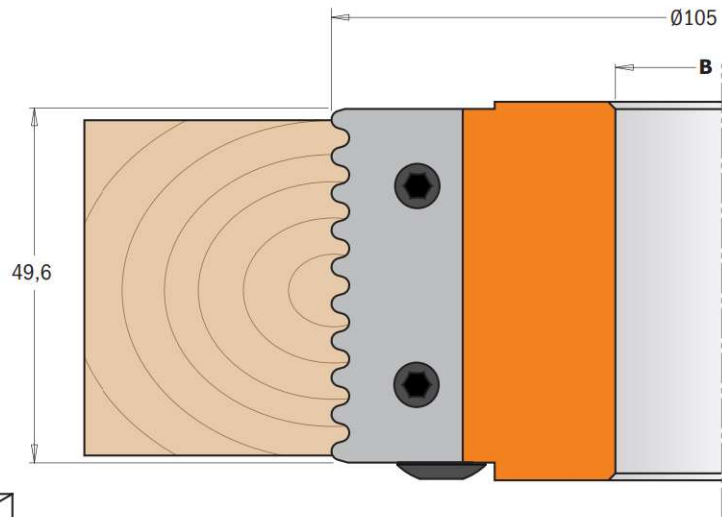

D mm	B mm	Z	RPM		ORDER NO.	Spare parts			
105	30	2	7300~11500	1	694.008.30	x2			
105	31,75	2	7300~11500	1	694.008.31	695.008.01	695.999.49	990.066.00	991.067.00
105	35	2	7300~11500	1	694.008.35	695.008.01	695.999.49	990.066.00	991.067.00
105	40	2	7300~11500	1	694.008.40	695.008.01	695.999.49	990.066.00	991.067.00
105	50	2	7300~11500	1	694.008.50	695.008.01	695.999.49	990.066.00	991.067.00

Optional

695.998.2630	Ø50x2,6x30mm guide ring
695.998.2631	Ø50x2,6x31,75mm guide ring
695.998.2635	Ø55x2,6x35mm guide ring
695.998.2640	Ø60x2,6x40mm guide ring
695.998.2650	Ø70x2,6x50mm guide ring

Reverse Glue Joint Cutter Heads



694.009

Darbagaldi & Instrumenti



TECHNICAL DETAILS:

- Hard aluminium alloy body with high resistance to tensile and yield stress.
- 2 HWM knives 40x18x2mm [Z2].
- Tools for manual feed (MAN).
- Pins for the automatic positioning of the knives.

Supplied in a solid plastic box.

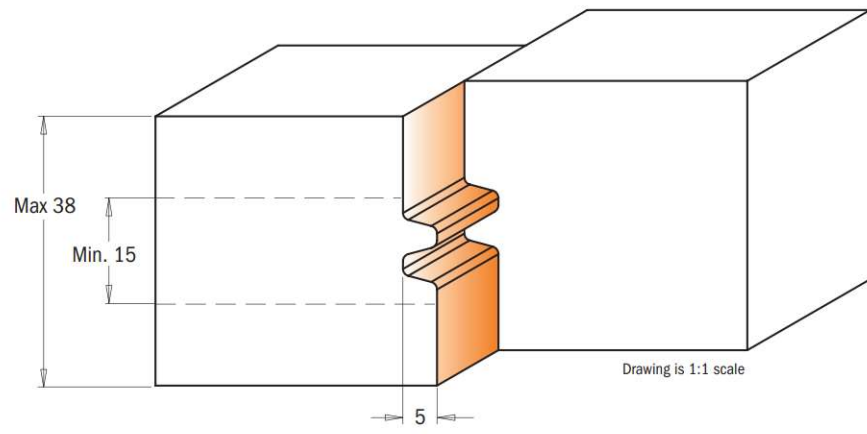
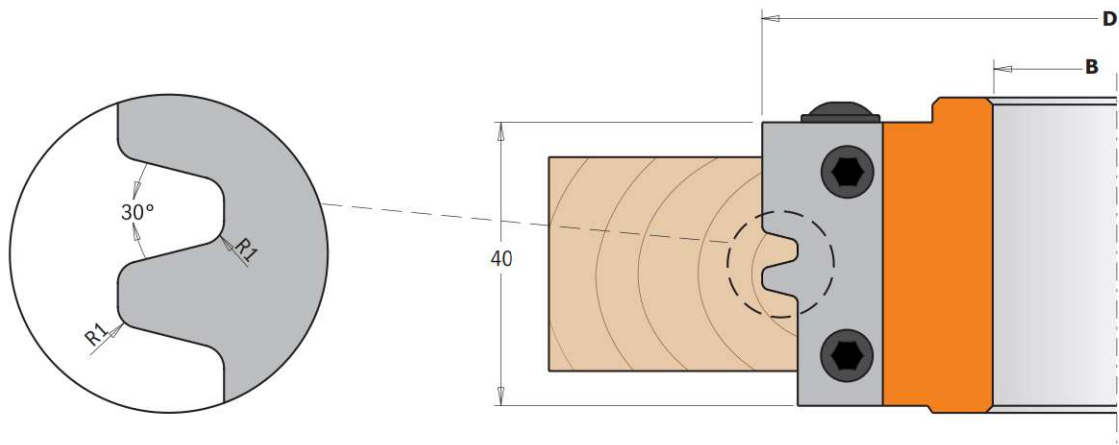

D mm	B mm	Z	RPM		ORDER NO.	Spare parts			
100	30	2	7500~12500	1	694.009.30	x2			
100	31,75	2	7500~12500	1	694.009.31	695.009.01	695.999.38	990.064.00	991.064.00
100	35	2	7500~12500	1	694.009.35	695.009.01	695.999.38	990.064.00	991.064.00
120	40	2	6400~10500	1	694.009.40	695.009.01	695.999.38	990.064.00	991.064.00
120	50	2	6400~10500	1	694.009.50	695.009.01	695.999.38	990.064.00	991.064.00

45° Lock Miter Cutter Heads



Darbagaldi & Instrumenti



694.011

CMT's lock miter cutter heads are ideal for milling miter joints in stock with maximum 28mm in thickness. Create boxes, stretcher bars, frames and any assortment of right angle or parallel joint projects. Two easy steps to produce perfect fitting 45° miter joints: first, position your workpiece horizontally, then vertically. Also, create parallel glue joints in two steps: place your workpiece horizontally, internal side facing down, and then turn it facing up. For use on spindle moulder and shaper machines. Perfect on all materials, but ideal on solid wood and panels.

TECHNICAL DETAILS:

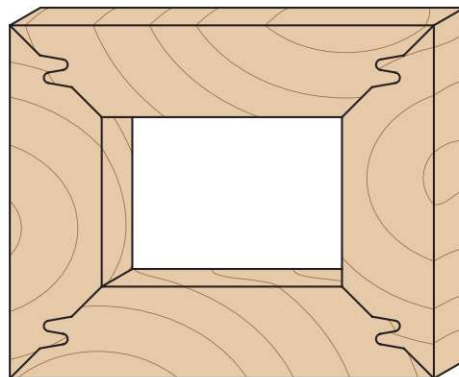
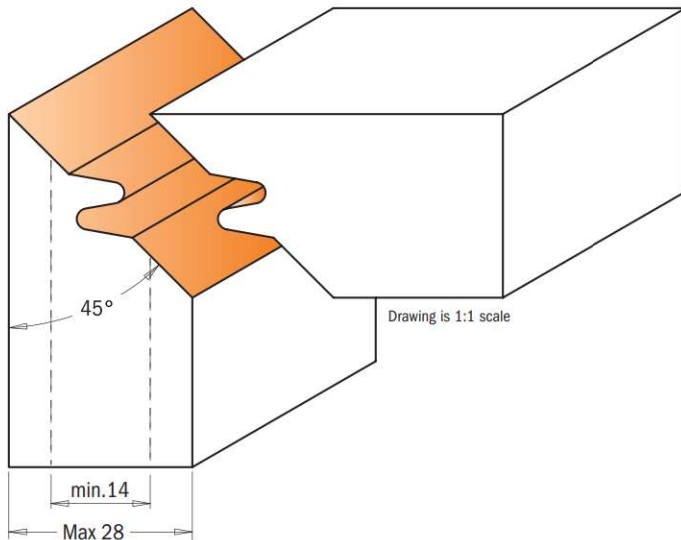
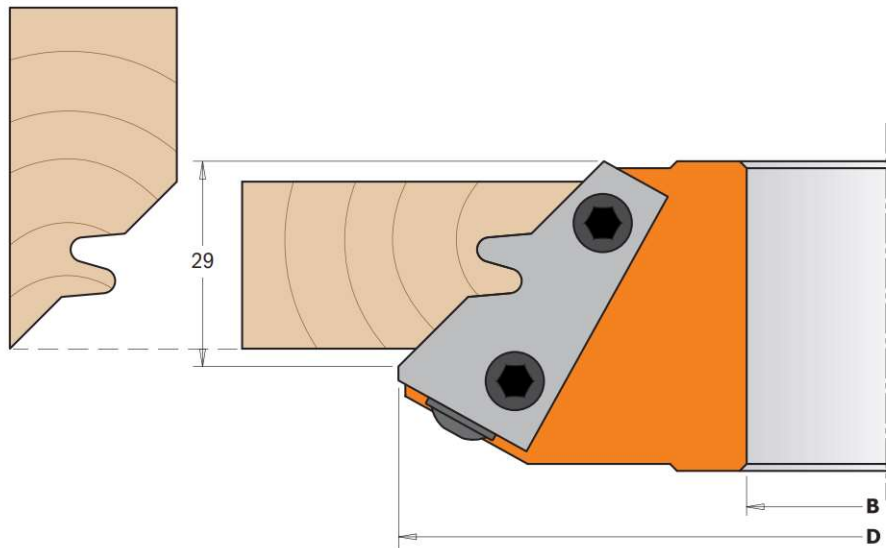

- Hard aluminium alloy body with high resistance to tensile and yield stress.
- 2 HWM knives 43x23x2mm [Z2].
- Tools for manual feed (MAN).
- Pins for the automatic positioning of the knives.

Supplied in a solid plastic box.



D mm	B mm	Z	RPM		ORDER NO.
140	30	2	5500~9500	1	694.011.30
140	31,75	2	5500~9500	1	694.011.31
140	35	2	5500~9500	1	694.011.35
140	40	2	5500~9500	1	694.011.40
150	50	2	5100~8800	1	694.011.50

Spare parts

 x2			
695.011.01	695.999.42	990.064.00	991.064.00
695.011.01	695.999.42	990.064.00	991.064.00
695.011.01	695.999.42	990.064.00	991.064.00
695.011.01	695.999.42	990.064.00	991.064.00
695.011.01	695.999.42	990.064.00	991.064.00



Raised Panel Cutter Heads



694.012 Darbagaldi & Instrumenti

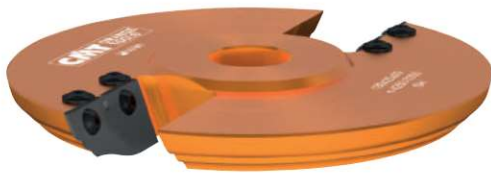

These new CMT cutter heads will allow you to make classic raised panels on furniture, interior and cabinet doors. An exceptional tool that makes up to six different profiles using the optional knives included. A practical and economical solution. We recommend multiple passes for safe and accurate finishing. For use on spindle moulders. Perfect for all materials, but ideal on solid wood and panels.

Supplied in a solid plastic box.

TECHNICAL DETAILS:

- Hard aluminium alloy body with high resistance to tensile and yield stress.
- 2 HWM Knives type (A) 50x25x2mm [Z2].
- Tools for manual feed (MAN)
- Pins for the automatic positioning of the knives.

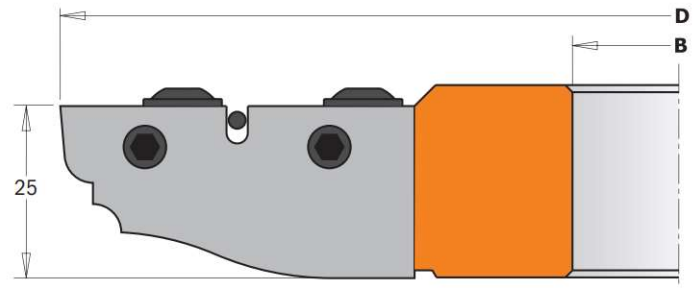

Standard

Pair of knives **695.012A**

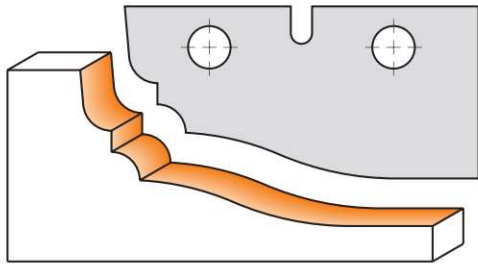

Drawing is 1:1 scale

Optional

Pair of knives **695.012B**



Pair of knives **695.012D**

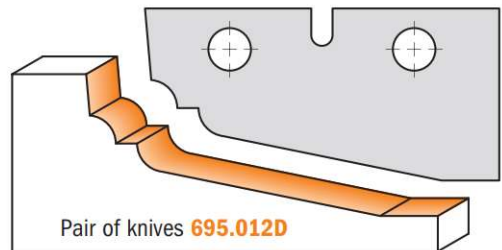

Pair of knives **695.012G**

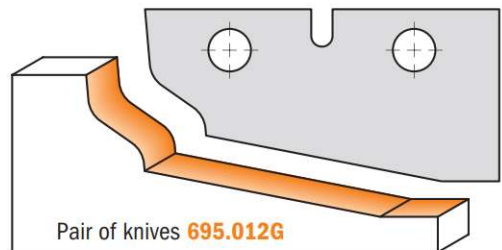

Pair of knives **695.012C**

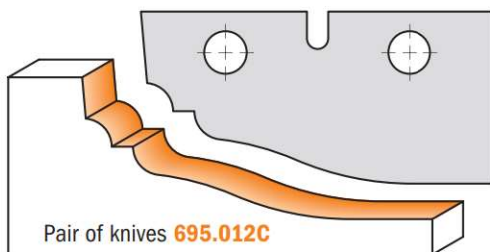

Pair of knives **695.012E**



D mm	I mm	B mm	Z	RPM		ORDER NO.	Spare parts		
180	25	30	2	4200~7000	1	694.012.30	x2		
180	25	35	2	4200~7000	1	694.012.35	695.012A	990.107.00	991.067.00
180	25	40	2	4200~7000	1	694.012.40	695.012A	990.107.00	991.067.00
180	25	50	2	4200~7000	1	694.012.50	695.012A	990.107.00	991.067.00

Optional	695.012B	50x25x2mm pair of knives type (B)	695.012E	50x25x2mm pair of knives type (E)
	695.012C	50x25x2mm pair of knives type (C)	695.012G	50x25x2mm pair of knives type (G)
	695.012D	50x25x2mm pair of knives type (D)		

Professional Raised Panel Cutter Heads



Darbagaldi & Instrumenti



694.013

We offer a traditional approach to panel construction with these CMT raised panel cutter heads. Make classic raised panels on furniture, interior and cabinet doors on solid wood and wooden boards, and achieve three different profiles by adjusting the cutting depth. We recommend multiple passes for safe and accurate finishing. For use on spindle moulders. Perfect for all materials, but ideal on solid wood and panels.

TECHNICAL DETAILS:

- Hard aluminium alloy body with high resistance to tensile and yield stress.
- 2 HWM Knives type (A) 19,8x11,9x1,5mm [Z2].
- 2 HWM Knives type (B) 60x11,9x1,5mm [Z2].
- Tools for manual feed (MAN).
- Pins for the automatic positioning of the knives.

Supplied in a solid plastic box.

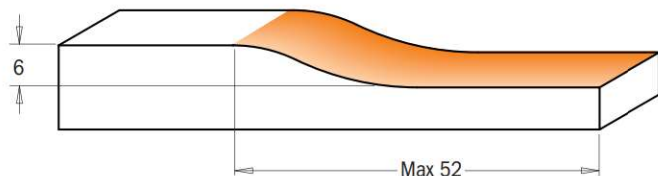
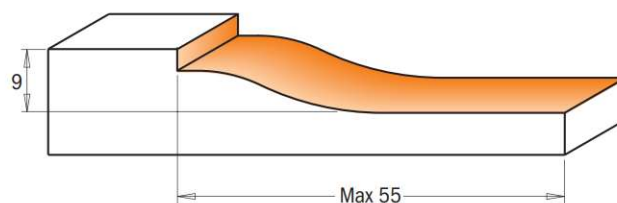
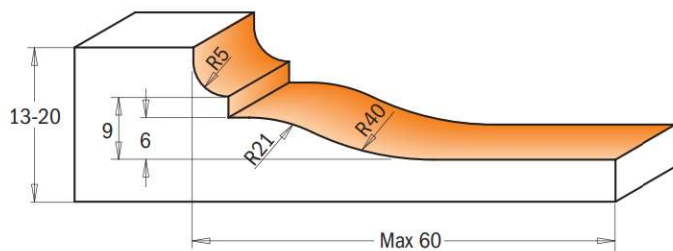
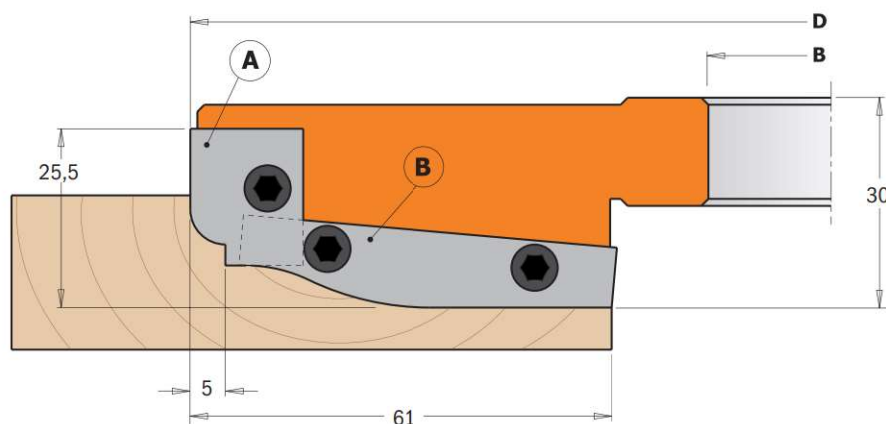

Drawing is 1:1 scale

D mm	B mm	Z	RPM		ORDER NO.	Spare parts				
						x2	16x11x9,5mm	x2	53x11x9,5mm	
183	30	2+2	4100~7000	1	694.013.30	695.013.A1	695.999.16	695.013.A2	695.999.53	990.066.00
183	31,75	2+2	4100~7000	1	694.013.31	695.013.A1	695.999.16	695.013.A2	695.999.53	990.066.00
183	35	2+2	4100~7000	1	694.013.35	695.013.A1	695.999.16	695.013.A2	695.999.53	990.066.00
200	40	2+2	3800~6400	1	694.013.40	695.013.A1	695.999.16	695.013.A2	695.999.53	990.066.00
200	50	2+2	3800~6400	1	694.013.50	695.013.A1	695.999.16	695.013.A2	695.999.53	990.066.00

Spare parts 991.083.00 3x90x135mm hex key

Profile & Counter Profile Cutter Head Sets



694.015

Darbagaldi & Instrumenti



TECHNICAL DETAILS:

- Hard aluminium alloy body with high resistance to tensile and yield stress for cutter heads (1 & 2).
- Super-strength steel body for cutter head (3).
- 2 HWM knives type (A1) 25x29,8x2mm [Z2].
- 2 HWM knives type (A2) 25x29,8x2mm [Z2].
- 4 HWM knives 7,65x12x1,5mm [Z4].
- 4 HWM knives 14x14x2mm for heads type (1 & 2).
- 12 spacer rings from 0,1 to 3mm for heads type (1 & 2).
- 12 spacer rings from 0,1 to 2mm for heads type (3).
- Tools for manual feed (MAN).
- Pins for the automatic positioning of the knives.

Supplied in a solid plastic box.

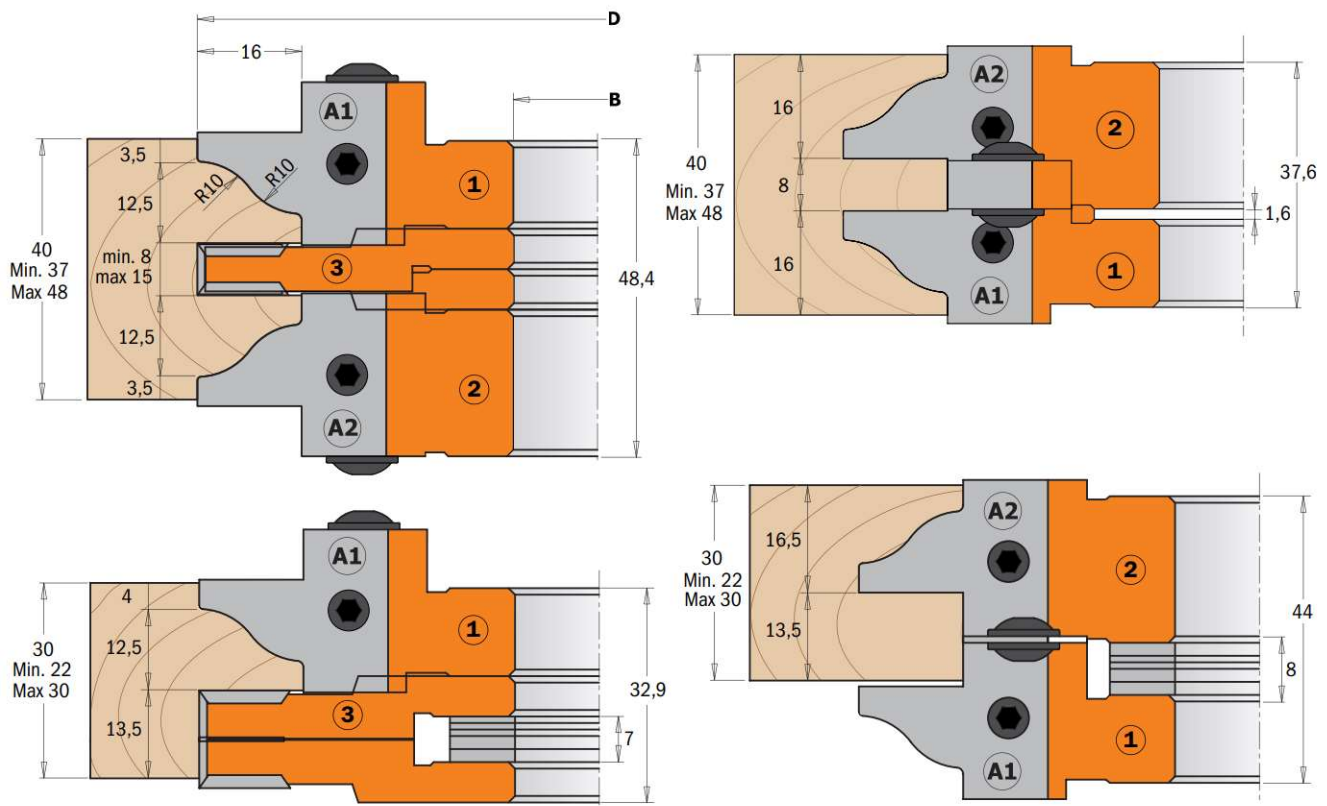

D mm	B mm	Z+V	RPM		ORDER NO.
132	30	2+4	5700-9500	1	694.015.30
132	31,75	2+4	5700-9500	1	694.015.31
132	35	2+4	5700-9500	1	694.015.35
147	40	2+4	5100-8500	1	694.015.40
147	50	2+4	5100-8500	1	694.015.50

Spare parts

695.998.01	695.998.21	695.998.30
695.998.02	695.998.22	695.998.31
695.998.03	695.998.23	695.998.35
695.998.04	695.998.24N	695.998.40
695.998.05	695.998.25N	

Spare parts

Head type (1)

695.015.A1	25x29,8x2mm HWM pair of knives (A1)
695.015.B1	25x29,8x2mm HWM pair of knives (B1)
695.015.C1	25x29,8x2mm HWM pair of knives (C1)
695.015.D1	25x29,8x2mm HWM pair of knives (D1)
695.015.E1	25x29,8x2mm HWM pair of knives (E1)
695.999.23	23x11x9,5mm wedge for knives
990.066.00	M6x16mm screw
991.067.00	3mm hex key

Head type (2)

695.015.A2	25x29,8x2mm HWM pair of knives (A2)
695.015.B2	25x29,8x2mm HWM pair of knives (B2)
695.015.C2	25x29,8x2mm HWM pair of knives (C2)
695.015.D2	25x29,8x2mm HWM pair of knives (D2)
695.015.E2	25x29,8x2mm HWM pair of knives (E2)
695.999.24	23x11x9,5mm wedge for knives
990.066.00	M6x16mm screws
991.067.00	3mm hex key

Head type (3)

790.076.00	7,65x12x1,5mm HWM knives
695.999.07	6,8x11x9,5mm wedge for knives
990.063.00	M5x18mm screw
991.072.00	T20 hex key
790.140.00	14x14x2mm HWM Knives
990.080.00	M5x6,5mm screw
991.073.00	T25 hex key

790.076.00 and 790.140.00 are supplied in 10-piece pack or multiple

www.cmtorangetools.com

Standard

Pair of knives **695.015.A1** - Pair of knives **695.015.A2**

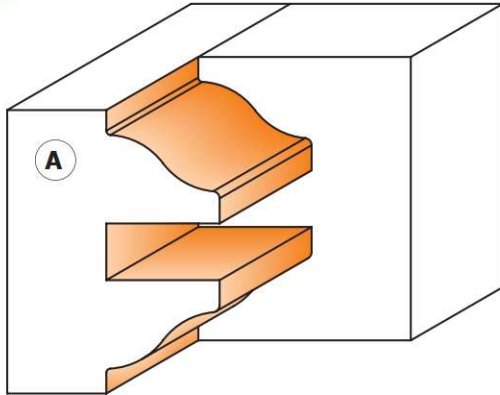

Drawing is 1:1 scale

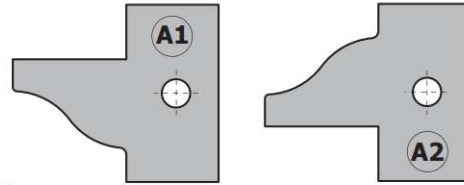

Optional

Pair of knives **695.015.B1**
Pair of knives **695.015.B2**

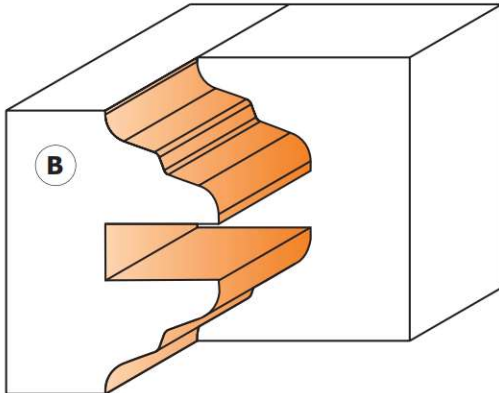
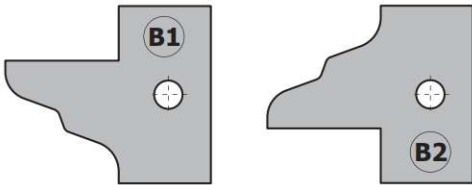

Pair of knives **695.015.C1**
Pair of knives **695.015.C2**

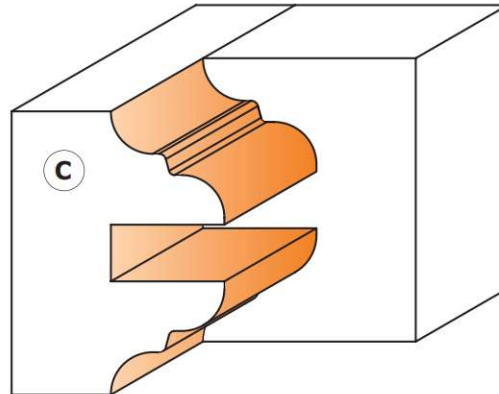
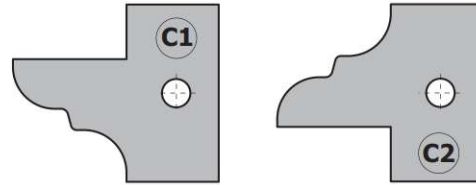

Pair of knives **695.015.D1**
Pair of knives **695.015.D2**

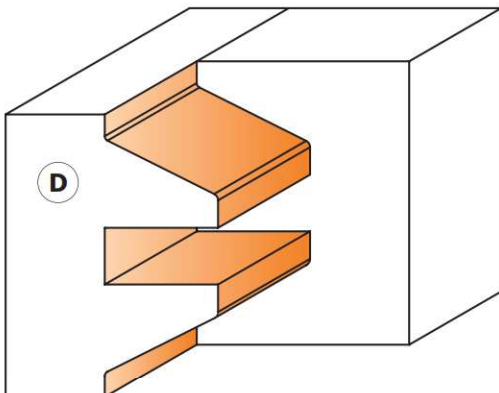
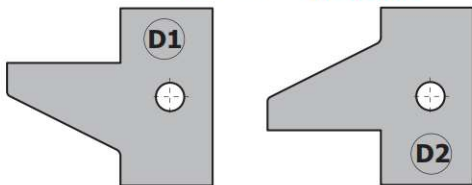

Pair of knives **695.015.E1**
Pair of knives **695.015.E2**

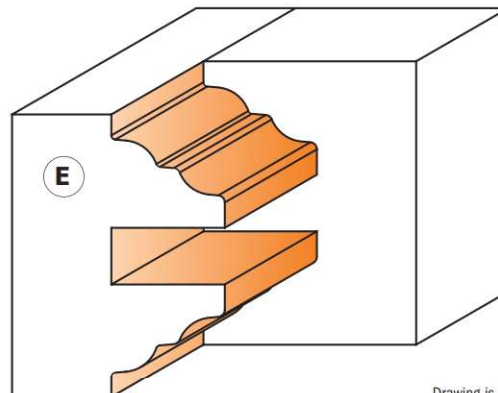
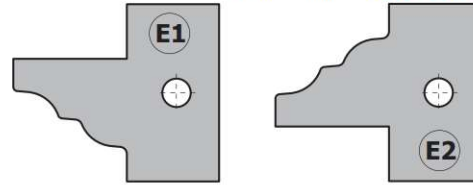

Drawing is 1:1 scale



1 Piece Rail & Stile Cutter Heads



694.014

Darbagaldi & Instrumenti



These are unique products made by combining two cutter heads, ideal for making furniture doors and drawers. By adjusting the height of the of the cutter head, you can cut two perfectly fitted profiles without wasting time or effort on the fence or replacing the tool. Improve your efficiency and save money only having to purchase one single cutter head!!! For use on spindle moulers. Perfect on hardwood and panels between 22mm-25mm in thickness.

TECHNICAL DETAILS:

- Hard aluminium alloy body with high resistance to tensile and yield stress.
- 2 HWM Knives type (A) 40x24,5x2mm [Z2].
- Tools for manual feed (MAN).
- Pins for the automatic positioning of the knives.

Supplied in a solid plastic box.



Standard

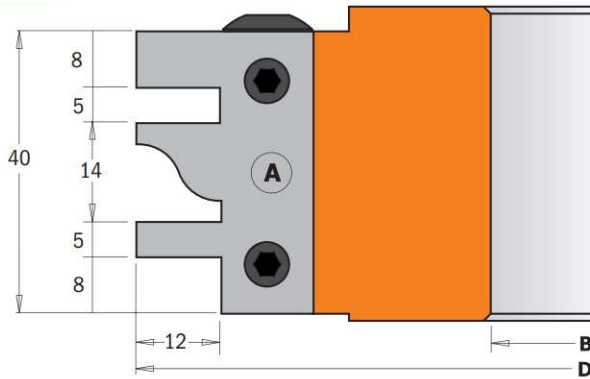

Pair of knives **695.014A**

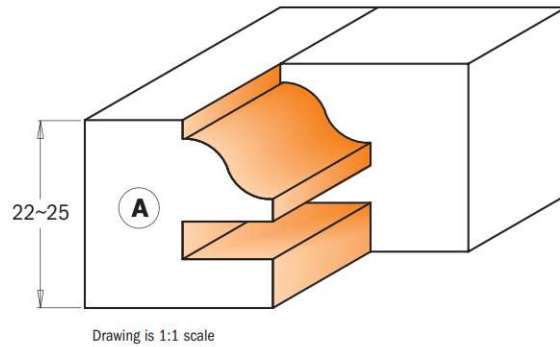

Optional

Pair of knives **695.014B**

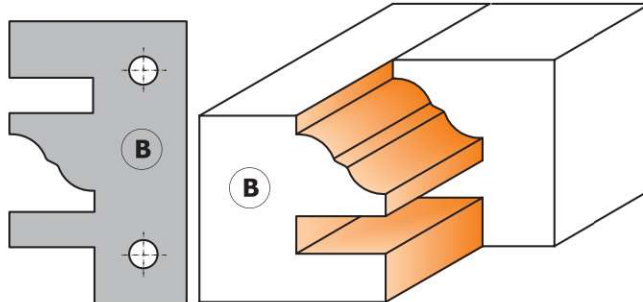

Pair of knives **695.014C**

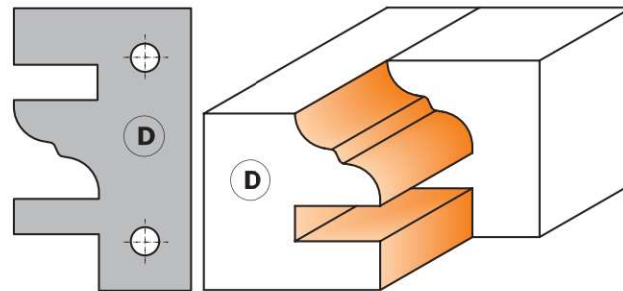
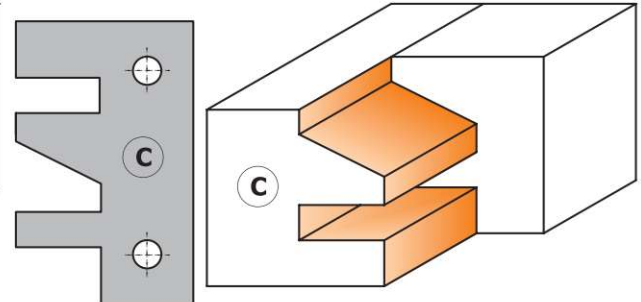

Drawing is 1:1 scale

Pair of knives **695.014D**

D mm	B mm	Z	RPM		ORDER NO.	Spare parts			
120	30	2	6400~10500	1	694.014.30	x2			
120	31,75	2	6400~10500	1	694.014.31	695.014A	695.999.39	990.066.00	991.067.00
120	35	2	6400~10500	1	694.014.35	695.014A	695.999.39	990.066.00	991.067.00
120	40	2	6400~10500	1	694.014.40	695.014A	695.999.39	990.066.00	991.067.00
130	50	2	5900~9700	1	694.014.50	695.014A	695.999.39	990.066.00	991.067.00

Optional
 695.014B 40x24,5x2mm pair of knives type (B)
 695.014C 40x24,5x2mm pair of knives type (C)
 695.014D 40x24,5x2mm pair of knives type (D)

Cutter Heads without Limiters

Darbagaldi & Instrumenti



692

CMT cutter heads guarantee excellent performance for all your projects. For use on all types of moulder and spindle moulder machines.

TECHNICAL DETAILS:

- Hard aluminium or steel alloy cutter head without limiters, highly resistant to tensile and yield stress.
- Pair of universal straight knives included.
- Tools for mechanical feed (MEC).
- Pins for the automatic positioning of the knives.
- Possibility to use knives with a height of 40mm or 50mm (order no. 690).



Supplied in a solid plastic box to contain up to 12 couples of knives.

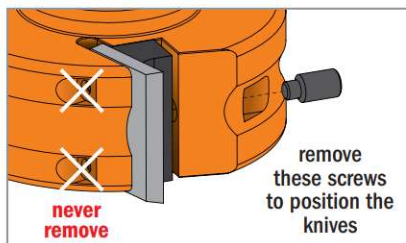

remove these screws to position the knives

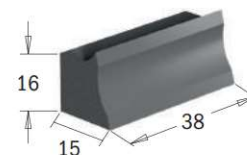
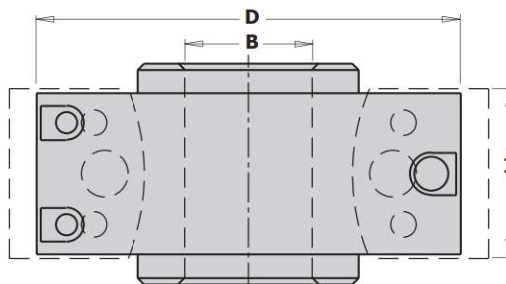

D mm	I mm	B mm	RPM		ORDER NO. Steel body	ORDER NO. Aluminium body	Spare parts		
78	40	19,05	7000~9000	1		692.078.19*			
78	40	30	7000~9000	1		692.078.30*	692.999.01	990.064.00	991.064.00
100	40-50	25,4	5500~8400	1		692.100.26	692.999.01	990.064.00	991.064.00
100	40-50	30	5500~8400	1	692.101.30	692.100.30	692.999.01	990.064.00	991.064.00
100	40-50	31,75	5500~8400	1		692.100.31	692.999.01	990.064.00	991.064.00
100	40-50	35	5500~8400	1	692.101.35	692.100.35	692.999.01	990.064.00	991.064.00
120	40-50	50	4800~7400	1	692.121.50	692.120.50	692.999.01	990.064.00	991.064.00

*For safety reasons we recommend the use of knives with a 40mm height only.

Cutter Heads with Limiters



693

CMT cutter heads guarantee excellent performance for all your projects. For use on all types of moulder and spindle moulder machines.

TECHNICAL DETAILS:

- Hard aluminium or steel alloy cutter head with limiters, highly resistant to tensile and yield stress.
- Pair of universal straight knives and limiters included.
- Tools for manual feed (MAN).
- Pins for the automatic positioning of the knives.
- Possibility to use knives with a height of 40mm or 50mm (order no. 690) and limiters (order no. 691).



Made in compliance with EU Directive EN 847-1.

Supplied in a solid plastic box to contain up to 12 couples of knives.

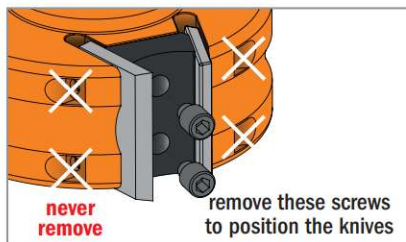

remove these screws to position the knives

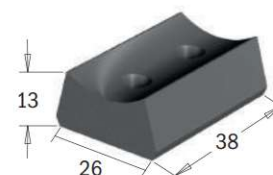
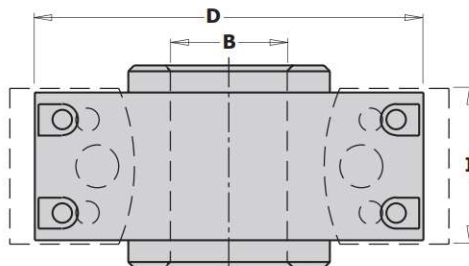

D mm	I mm	B mm	RPM		ORDER NO. Steel body	ORDER NO. Aluminium body	Spare parts		
78	40	30	7000~9000	1	693.078.30				
100	40-50	30	5500~8400	1	693.101.30	693.100.30	693.999.01	990.065.00	991.064.00
100	40-50	31,75	5500~8400	1		693.100.31	693.999.01	990.065.00	991.064.00
100	40-50	35	5500~8400	1	693.101.35	693.100.35	693.999.01	990.065.00	991.064.00
120	40-50	50	4800~7400	1	693.121.50	693.120.50	693.999.01	990.065.00	991.064.00

13 Piece Multiprofile Cutter Head Sets without Limiters



692

These sets are ideal for making joints and frames and include 3 essential profiles specifically for crafting doors. An invaluable asset for any professional woodworker. The cutter heads included allow the insertion of knives at a height of either 40mm or 50mm. Both cutter head and knives are stored in solid plastic cases to prevent damage.

These sets include:

- 1 cutter head in hard aluminium alloy with pins for the automatic positioning of the knives.
- 13 pairs of knives with a cutting height of 40mm.

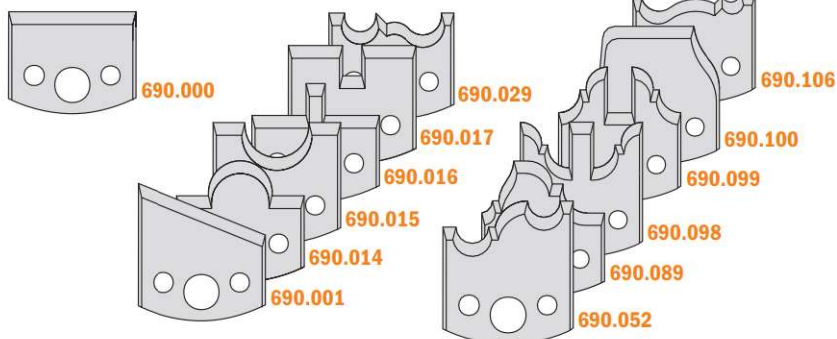
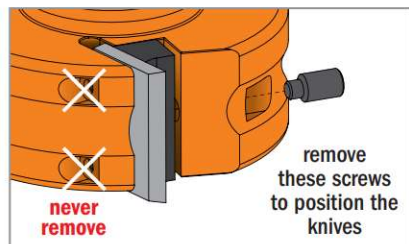

D mm	I mm	B mm	RPM		ORDER NO.
78	40	19,05	7000~9000	1	692.013.09
78	40	30	7000~9000	1	692.013.01
100	40	25,4	5500~8400	1	692.013.10
100	40	30	5500~8400	1	692.013.02
100	40	31,75	5500~8400	1	692.013.11
100	40	35	5500~8400	1	692.013.03
120	40	50	4800~7400	1	692.013.04

Spare parts

692.999.01	990.064.00	991.064.00
692.999.01	990.064.00	991.064.00
692.999.01	990.064.00	991.064.00
692.999.01	990.064.00	991.064.00
692.999.01	990.064.00	991.064.00
692.999.01	990.064.00	991.064.00
692.999.01	990.064.00	991.064.00
692.999.01	990.064.00	991.064.00



692

These sets include 13 profile knives for making joints, frames, multiple profiles, moldings and chamfers. Ideal for the professional woodworker. The cutter head included allows the insertion of knives at a height of either 40mm or 50mm. Both cutter head and knives are stored in solid plastic cases to prevent damage.

These sets include:

- 1 cutter head in hard aluminium alloy with pins for the automatic positioning of the knives.
- 13 pairs of knives with a cutting height of 40mm.

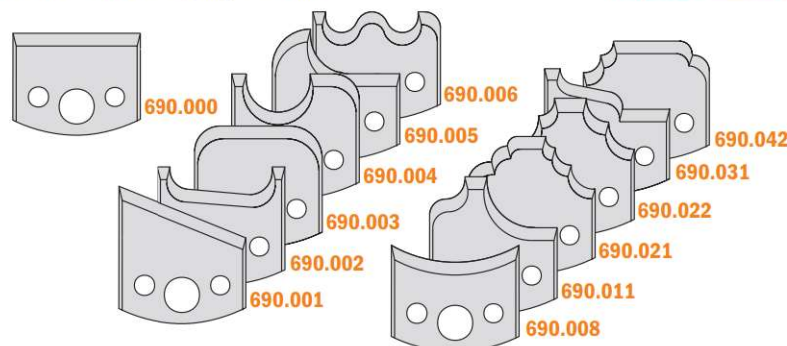
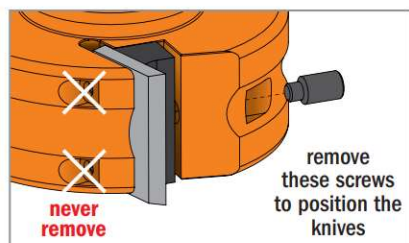

D mm	I mm	B mm	RPM		ORDER NO.
78	40	19,05	7000~9000	1	692.013.12
78	40	30	7000~9000	1	692.013.05
100	40	25,4	5500~8400	1	692.013.13
100	40	30	5500~8400	1	692.013.06
100	40	31,75	5500~8400	1	692.013.14
100	40	35	5500~8400	1	692.013.07
120	40	50	4800~7400	1	692.013.08

Spare parts

692.999.01	990.064.00	991.064.00
692.999.01	990.064.00	991.064.00
692.999.01	990.064.00	991.064.00
692.999.01	990.064.00	991.064.00
692.999.01	990.064.00	991.064.00
692.999.01	990.064.00	991.064.00
692.999.01	990.064.00	991.064.00

7 Piece Multiprofile Cutter Head Sets with Limiters

TBOX

CMT ORANGE TOOLS

Darbagaldi & Instrumenti



693

The professional woodworker now has the chance to make kitchen doors with a horizontal profile and male-and-female joints with two pairs of cutters. In fact, along with 7 profiled knives these sets also contain a specially designed cutter head that allows the insertion of knives with a height of either 40mm or 50mm, and safety limiters produced in compliance with the European Regulation EN 847-1. Both cutter head and knives are stored in solid plastic cases to prevent damage.

These sets include:

- 1 cutter head in hard aluminium alloy allowing the insertion of straight knives, limiters and pins for the automatic positioning of the knives.
- 7 pairs of knives with 40mm of cutting.
- 7 pairs of relative limiters.

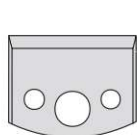

690.000
691.000

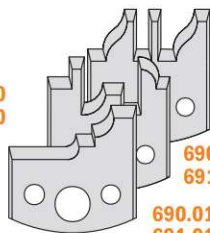

690.097
691.097
690.096
691.096
690.019
691.019

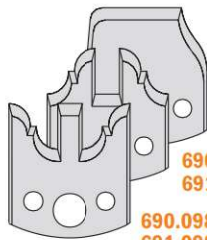

690.100
691.100
690.099
691.099
690.098
691.098

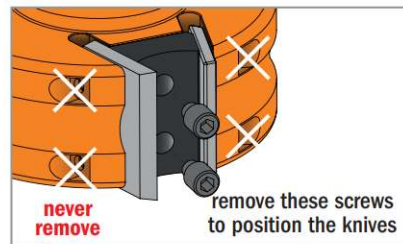

D mm	I mm	B mm	RPM		ORDER NO.
100	40	30	5500~8400	1	693.013.01
100	40	35	5500~8400	1	693.013.02
120	40	50	4800~7400	1	693.013.03

Spare parts

693.999.01	990.065.00	991.064.00
693.999.01	990.065.00	991.064.00
693.999.01	990.065.00	991.064.00

7 Piece Multiprofile Cutter Head Sets with Limiters



693

This set contains 7 profiles knives and a cutter head for making joints, frames and chamfers. The cutter heads allow the insertion of knives at a height of either 40mm or 50mm. Safety limiters are produced in compliance with EU Directive EN 847-1. both cutter head and knives are stored in solid plastic cases to prevent damage.

These sets include:

- 1 cutter head in hard aluminium alloy allowing the insertion of straight knives, limiters and pins for the automatic positioning of the knives.
- 7 pairs of knives with 40mm of cutting.
- 7 pairs of relative limiters.

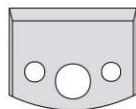

690.000
691.000

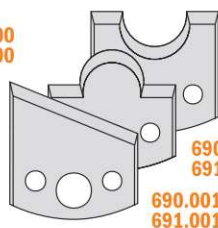

690.015
691.015
690.014
691.014
690.001
691.001

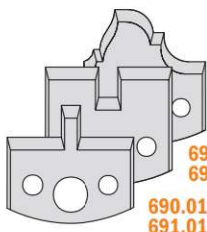

690.089
691.089
690.017
691.017
690.016
691.016

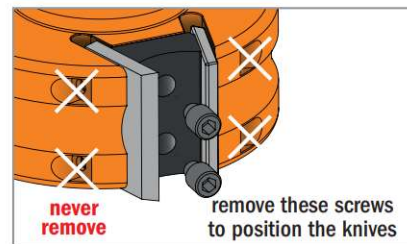

D mm	I mm	B mm	RPM		ORDER NO.
100	40	30	5500~8400	1	693.013.04
100	40	35	5500~8400	1	693.013.05
120	40	50	4800~7400	1	693.013.06

Spare parts

693.999.01	990.065.00	991.064.00
693.999.01	990.065.00	991.064.00
693.999.01	990.065.00	991.064.00

Profile Knives and Limiters

Cutting Length=40mm Thickness=4mm

Pack Qty. 10



SP

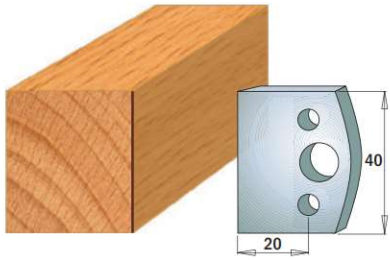

Pair of knives **690.000**
Pair of limiters **691.000**

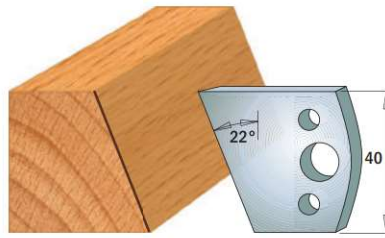

Pair of knives **690.001**
Pair of limiters **691.001**

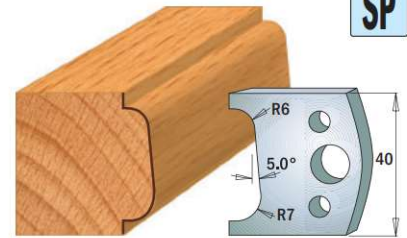

Pair of knives **690.002**
Pair of limiters **691.002**

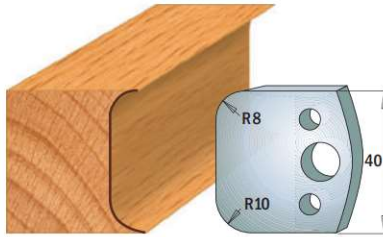

Pair of knives **690.003**
Pair of limiters **691.003**

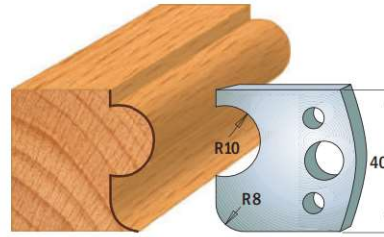

Pair of knives **690.004**
Pair of limiters **691.004**

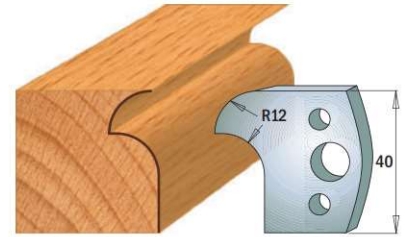

Pair of knives **690.005**
Pair of limiters **691.005**

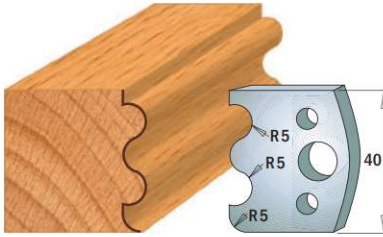

Pair of knives **690.006**
Pair of limiters **691.006**

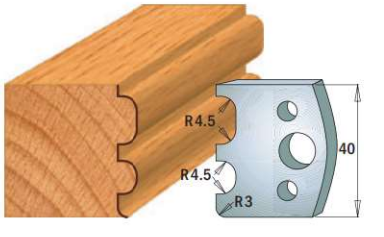

Pair of knives **690.007**
Pair of limiters **691.007**

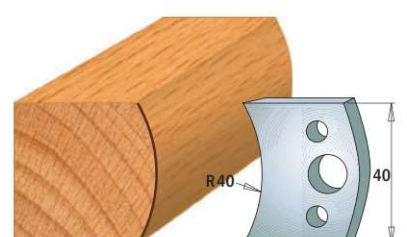

Pair of knives **690.008**
Pair of limiters **691.008**

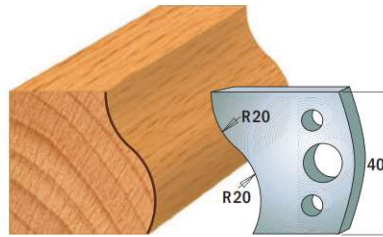

Pair of knives **690.009**
Pair of limiters **691.009**

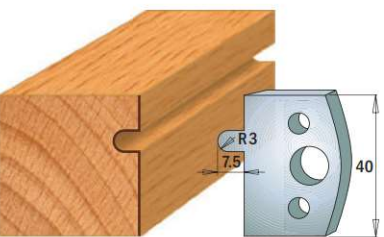

Pair of knives **690.010**
Pair of limiters **691.010**

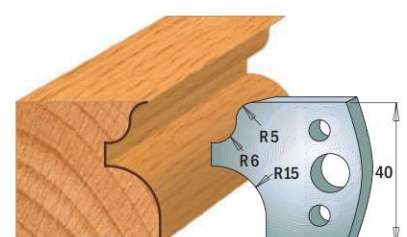

Pair of knives **690.011**
Pair of limiters **691.011**

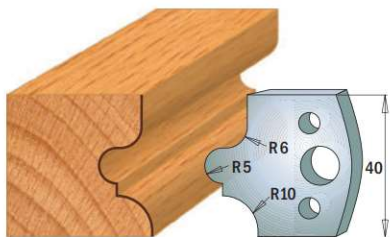

Pair of knives **690.012**
Pair of limiters **691.012**

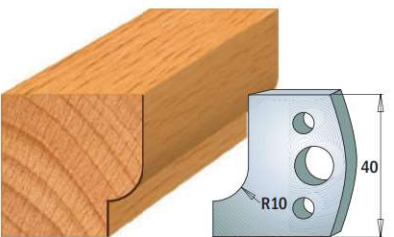

Pair of knives **690.013**
Pair of limiters **691.013**

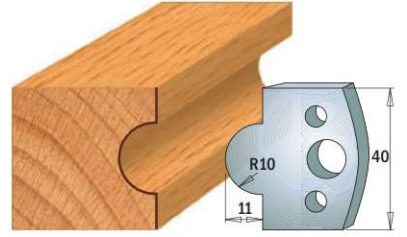

Pair of knives **690.014**
Pair of limiters **691.014**

NOTE: all knives & limiters available only in pairs

Drawings are 1:2 scale

Dimensions in mm.

Profile Knives and Limiters
Cutting Length=40mm Thickness=4mm

Pack Qty. 10



Darbagaldi & Instrumenti

SP

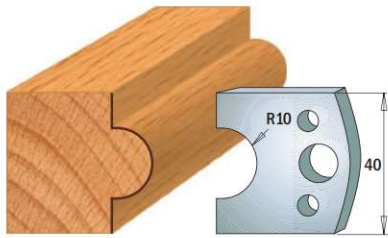

Pair of knives **690.015**
Pair of limiters **691.015**

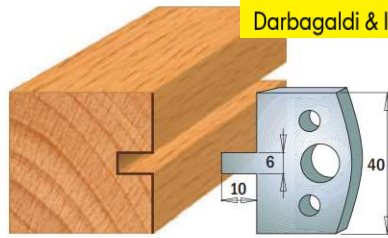

Pair of knives **690.016**
Pair of limiters **691.016**

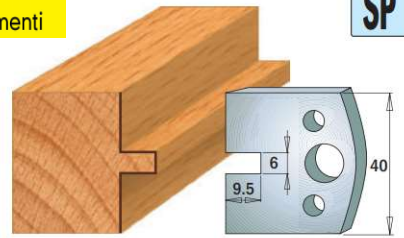

Pair of knives **690.017**
Pair of limiters **691.017**

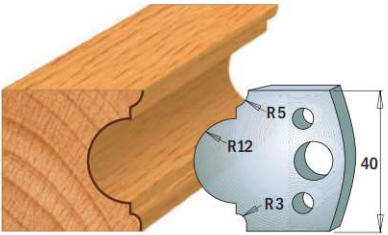

Pair of knives **690.018**
Pair of limiters **691.018**

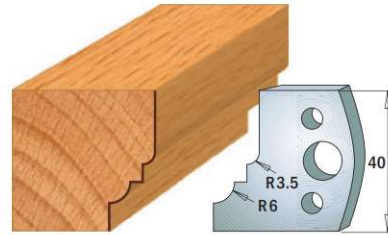

Pair of knives **690.019**
Pair of limiters **691.019**

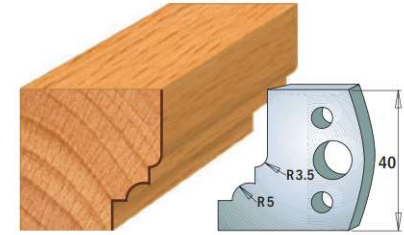

Pair of knives **690.020**
Pair of limiters **691.020**

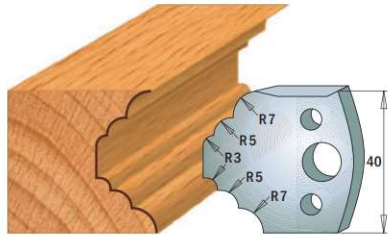

Pair of knives **690.021**
Pair of limiters **691.021**

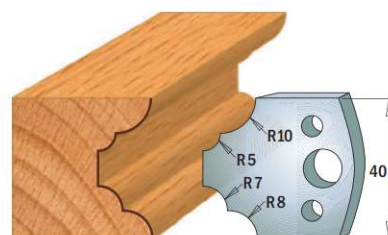

Pair of knives **690.022**
Pair of limiters **691.022**

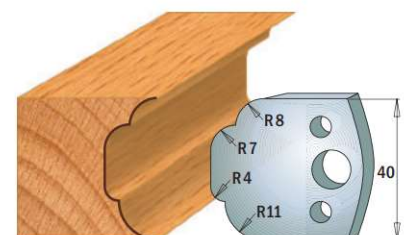

Pair of knives **690.023**
Pair of limiters **691.023**

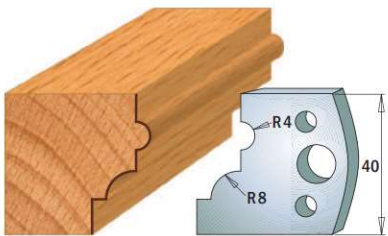

Pair of knives **690.024**
Pair of limiters **691.024**

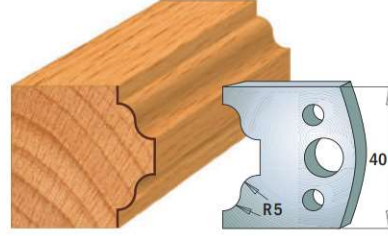

Pair of knives **690.025**
Pair of limiters **691.025**

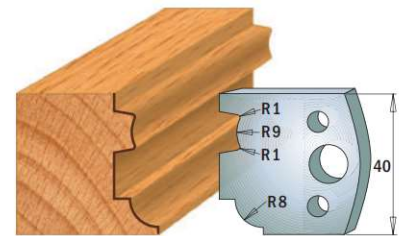

Pair of knives **690.026**
Pair of limiters **691.026**

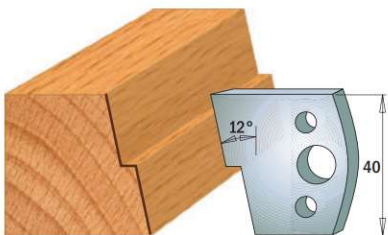

Pair of knives **690.027**
Pair of limiters **691.027**

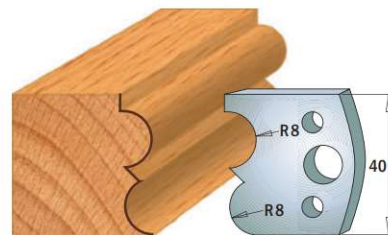

Pair of knives **690.028**
Pair of limiters **691.028**

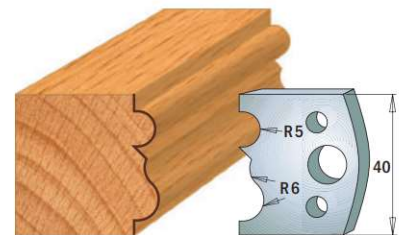

Pair of knives **690.029**
Pair of limiters **691.029**

NOTE: all knives & limiters available only in pairs

Drawings are 1:2 scale

Dimensions in mm.

Profile Knives and Limiters
Cutting Length=40mm Thickness=4mm

Pack Qty. 10

TBOX

CMT ORANGE TOOLS

Darbagaldi & Instrumenti

SP

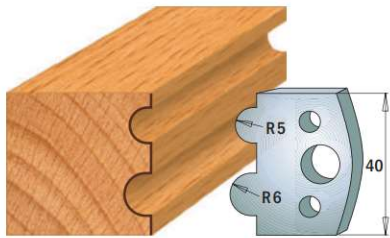

Pair of knives **690.030**
Pair of limiters **691.030**

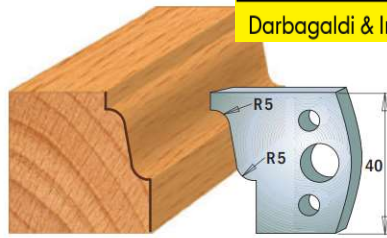

Pair of knives **690.031**
Pair of limiters **691.031**

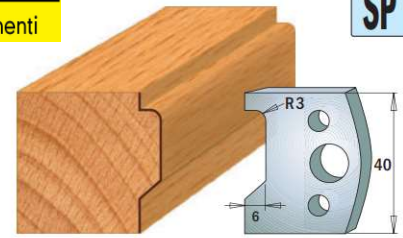

Pair of knives **690.032**
Pair of limiters **691.032**

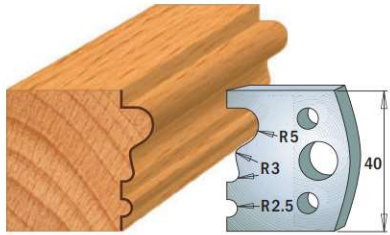

Pair of knives **690.033**
Pair of limiters **691.033**

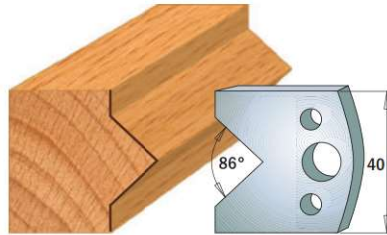

Pair of knives **690.034**
Pair of limiters **691.034**

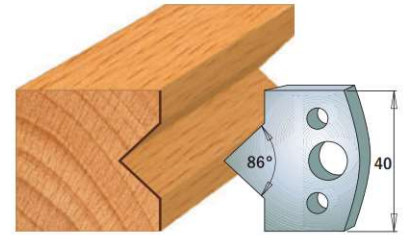

Pair of knives **690.035**
Pair of limiters **691.035**

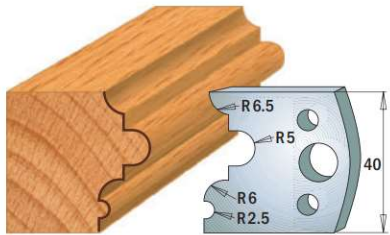

Pair of knives **690.036**
Pair of limiters **691.036**

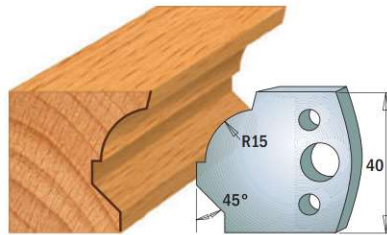

Pair of knives **690.037**
Pair of limiters **691.037**

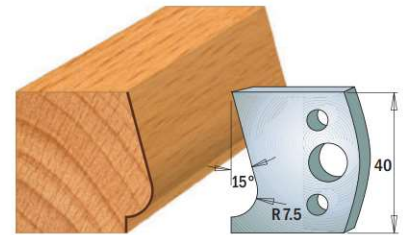

Pair of knives **690.038**
Pair of limiters **691.038**

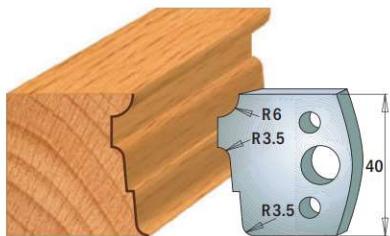

Pair of knives **690.039**
Pair of limiters **691.039**

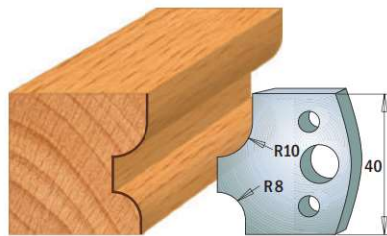

Pair of knives **690.040**
Pair of limiters **691.040**

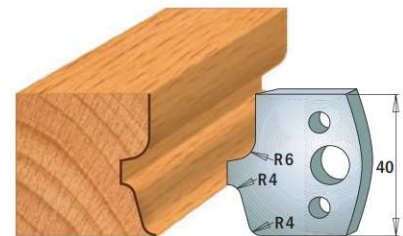

Pair of knives **690.041**
Pair of limiters **691.041**

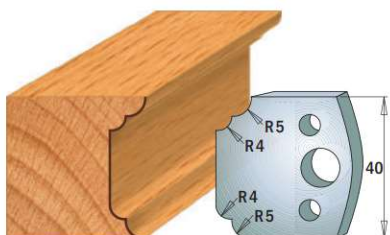

Pair of knives **690.042**
Pair of limiters **691.042**

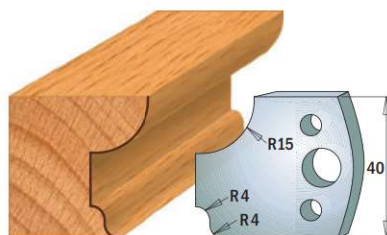

Pair of knives **690.043**
Pair of limiters **691.043**

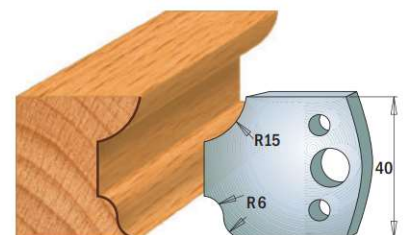

Pair of knives **690.044**
Pair of limiters **691.044**

NOTE: all knives & limiters available only in pairs

Drawings are 1:2 scale

Dimensions in mm.

Profile Knives and Limiters
Cutting Length=40mm Thickness=4mm

Pack Qty. 10



SP

Darbagaldi & Instrumenti

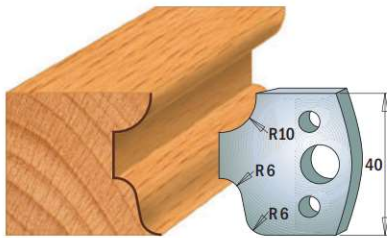

Pair of knives **690.045**
Pair of limiters **691.045**

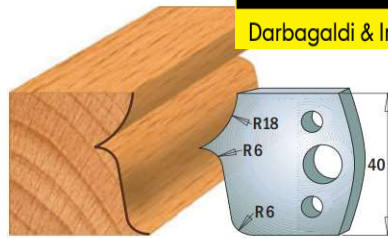

Pair of knives **690.046**
Pair of limiters **691.046**

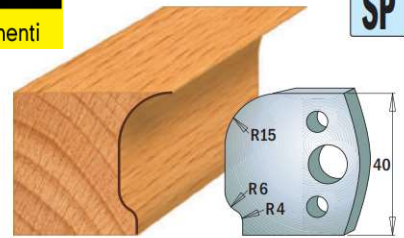

Pair of knives **690.047**
Pair of limiters **691.047**

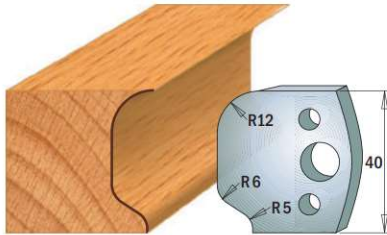

Pair of knives **690.048**
Pair of limiters **691.048**

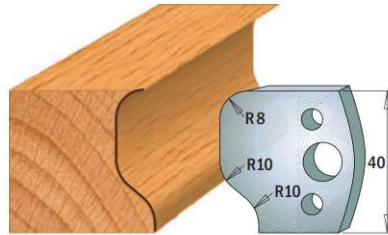

Pair of knives **690.049**
Pair of limiters **691.049**

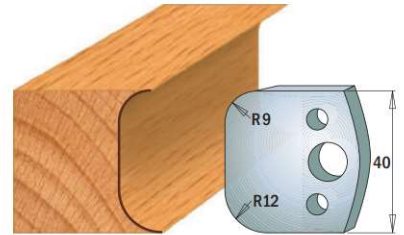

Pair of knives **690.050**
Pair of limiters **691.050**

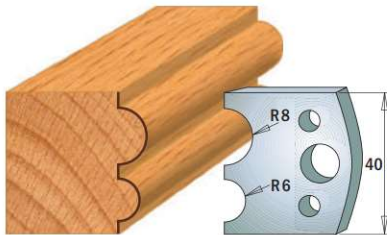

Pair of knives **690.051**
Pair of limiters **691.051**

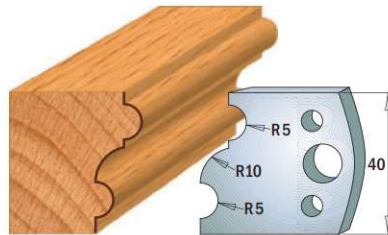

Pair of knives **690.052**
Pair of limiters **691.052**

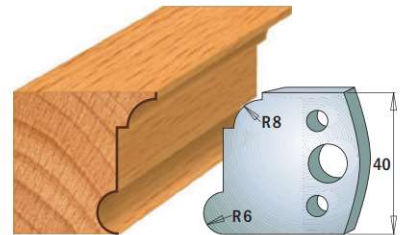

Pair of knives **690.053**
Pair of limiters **691.053**

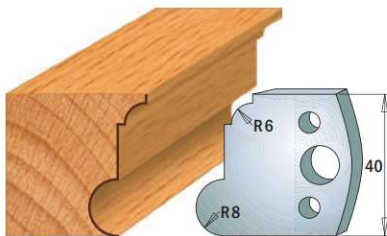

Pair of knives **690.054**
Pair of limiters **691.054**

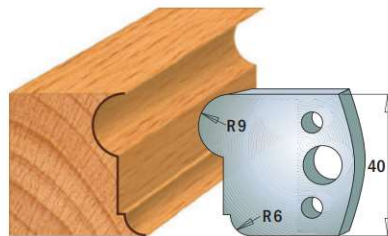

Pair of knives **690.055**
Pair of limiters **691.055**

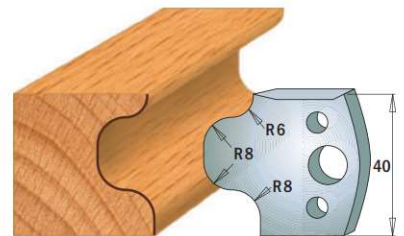

Pair of knives **690.056**
Pair of limiters **691.056**

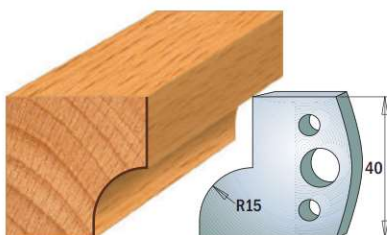

Pair of knives **690.057**
Pair of limiters **691.057**

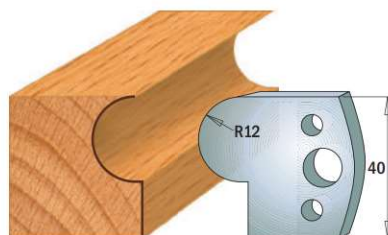

Pair of knives **690.058**
Pair of limiters **691.058**

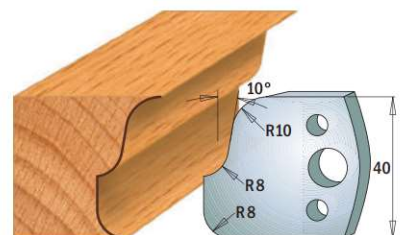

Pair of knives **690.059**
Pair of limiters **691.059**

NOTE: all knives & limiters available only in pairs

Drawings are 1:2 scale

Dimensions in mm.

Profile Knives and Limiters

Cutting Length=40mm Thickness=4mm

Pack Qty. 10

TBOX

CMT ORANGE TOOLS

SP

Darbagaldi & Instrumenti

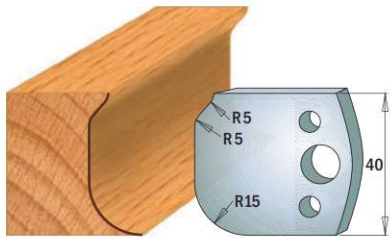

Pair of knives **690.060**
Pair of limiters **691.060**

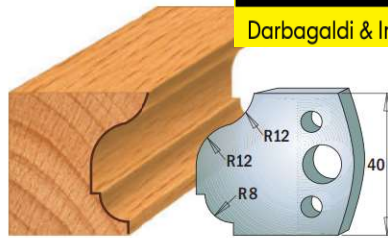

Pair of knives **690.061**
Pair of limiters **691.061**

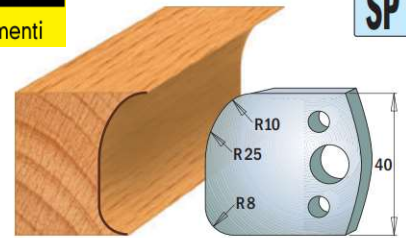

Pair of knives **690.062**
Pair of limiters **691.062**

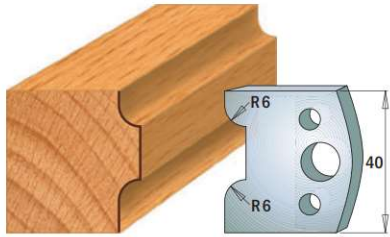

Pair of knives **690.063**
Pair of limiters **691.063**

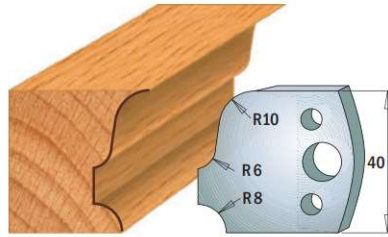

Pair of knives **690.064**
Pair of limiters **691.064**

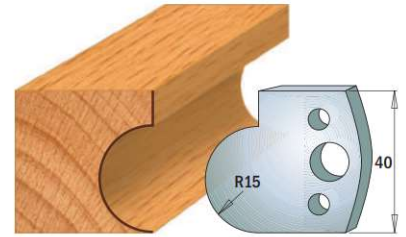

Pair of knives **690.065**
Pair of limiters **691.065**

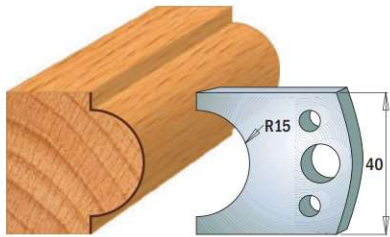

Pair of knives **690.066**
Pair of limiters **691.066**

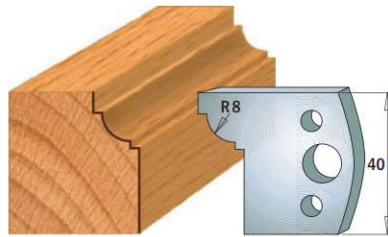

Pair of knives **690.067**
Pair of limiters **691.067**

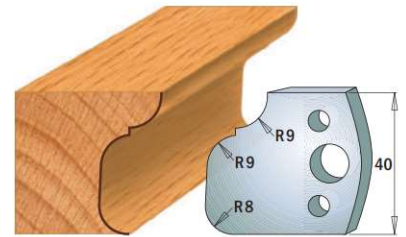

Pair of knives **690.068**
Pair of limiters **691.068**

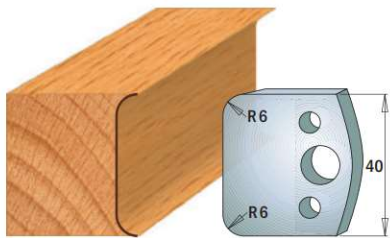

Pair of knives **690.069**
Pair of limiters **691.069**

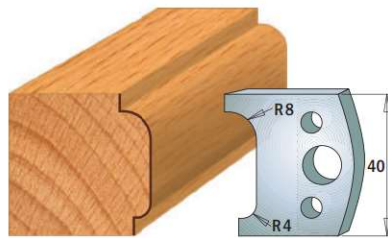

Pair of knives **690.070**
Pair of limiters **691.070**

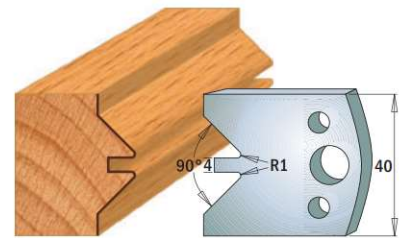

Pair of knives **690.071**
Pair of limiters **691.071**

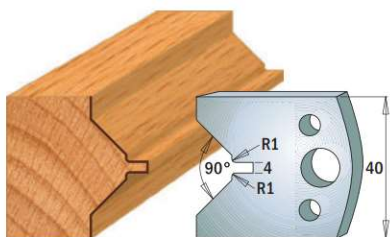

Pair of knives **690.072**
Pair of limiters **691.072**

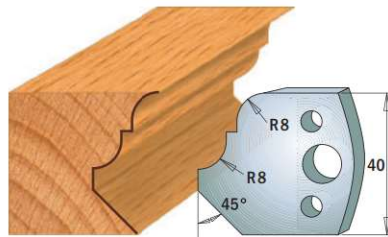

Pair of knives **690.073**
Pair of limiters **691.073**

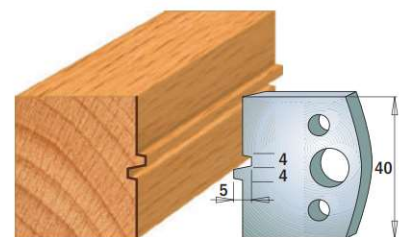

Pair of knives **690.074**
Pair of limiters **691.074**

NOTE: all knives & limiters available only in pairs

Drawings are 1:2 scale

Dimensions in mm.

Profile Knives and Limiters
Cutting Length=40mm Thickness=4mm

Pack Qty. 10



SP

Darbagaldi & Instrumenti

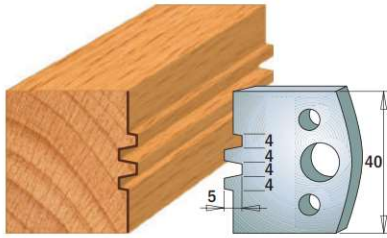

Pair of knives **690.075**
Pair of limiters **691.075**

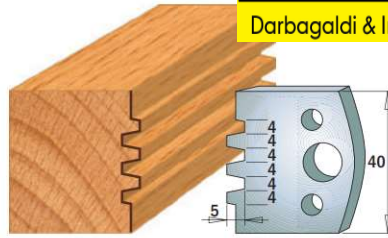

Pair of knives **690.076**
Pair of limiters **691.076**

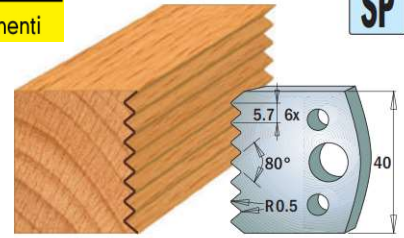

Pair of knives **690.077**
Pair of limiters **691.077**

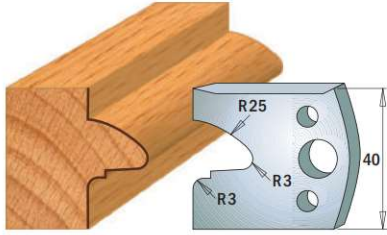

Pair of knives **690.078**
Pair of limiters **691.078**

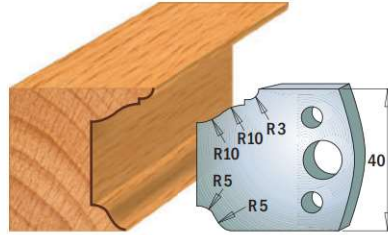

Pair of knives **690.079**
Pair of limiters **691.079**

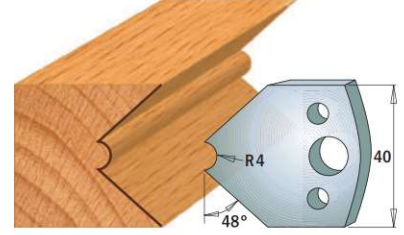

Pair of knives **690.080**
Pair of limiters **691.080**

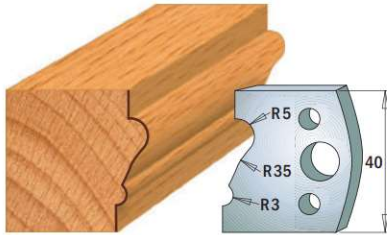

Pair of knives **690.081**
Pair of limiters **691.081**

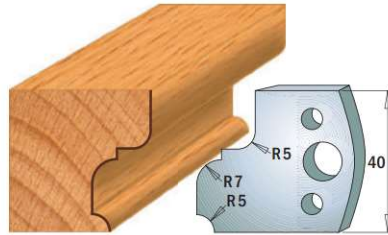

Pair of knives **690.082**
Pair of limiters **691.082**

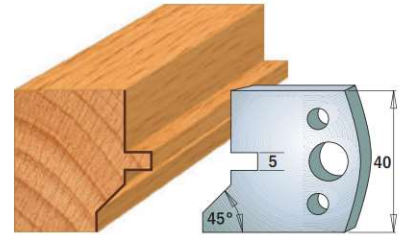

Pair of knives **690.083**
Pair of limiters **691.083**

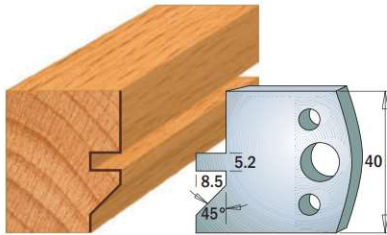

Pair of knives **690.084**
Pair of limiters **691.084**

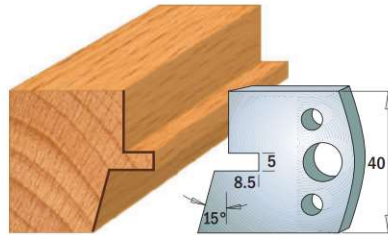

Pair of knives **690.085**
Pair of limiters **691.085**

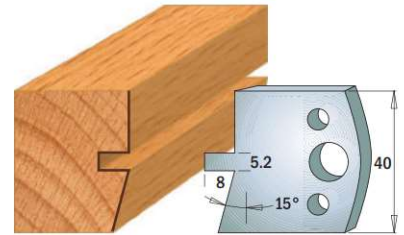

Pair of knives **690.086**
Pair of limiters **691.086**



Pair of knives **690.087**
Pair of limiters **691.087**

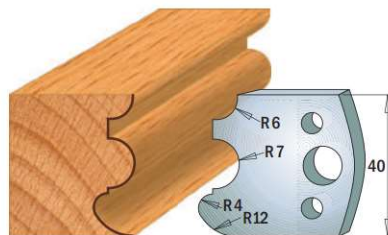

Pair of knives **690.088**
Pair of limiters **691.088**

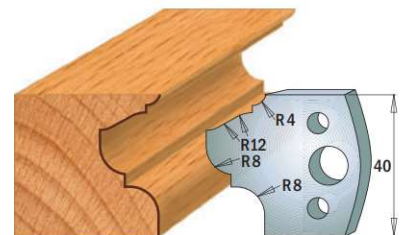

Pair of knives **690.089**
Pair of limiters **691.089**

NOTE: all knives & limiters available only in pairs

Drawings are 1:2 scale

Dimensions in mm.

Profile Knives and Limiters
Cutting Length=40mm Thickness=4mm

Pack Qty. 10

TBOX

CMT ORANGE TOOLS

SP

Darbagaldi & Instrumenti

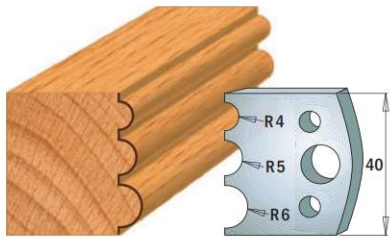

Pair of knives **690.090**
Pair of limiters **691.090**

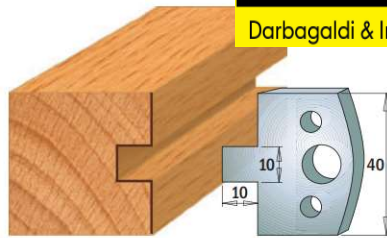

Pair of knives **690.091**
Pair of limiters **691.091**

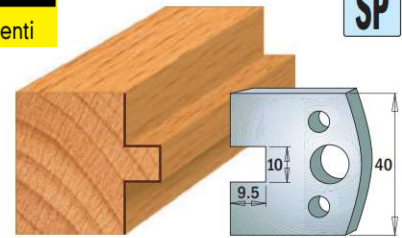

Pair of knives **690.092**
Pair of limiters **691.092**

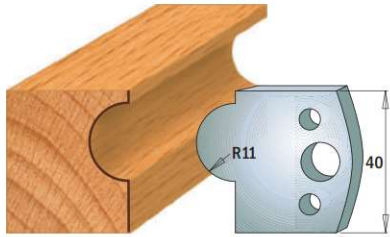

Pair of knives **690.093**
Pair of limiters **691.093**

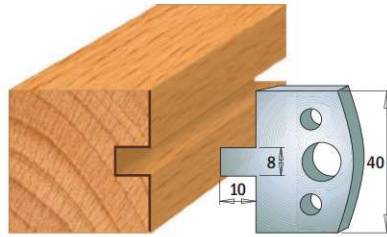

Pair of knives **690.094**
Pair of limiters **691.094**

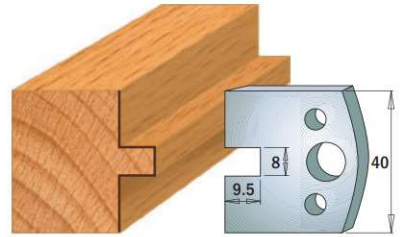

Pair of knives **690.095**
Pair of limiters **691.095**

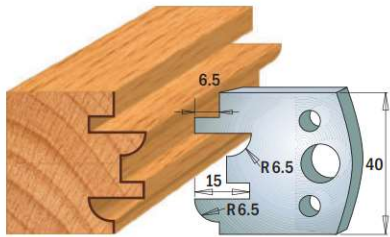

Pair of knives **690.096**
Pair of limiters **691.096**

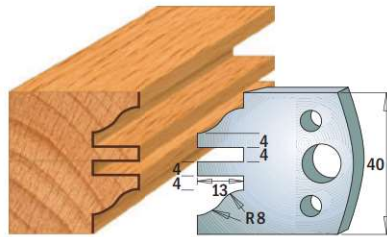

Pair of knives **690.097**
Pair of limiters **691.097**

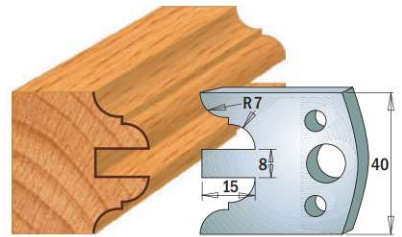

Pair of knives **690.098**
Pair of limiters **691.098**

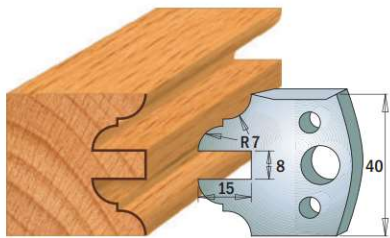

Pair of knives **690.099**
Pair of limiters **691.099**

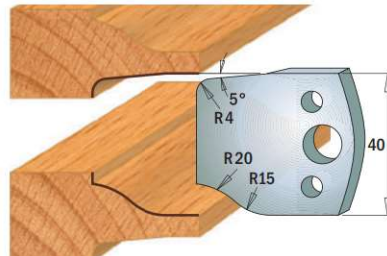

Pair of knives **690.100**
Pair of limiters **691.100**

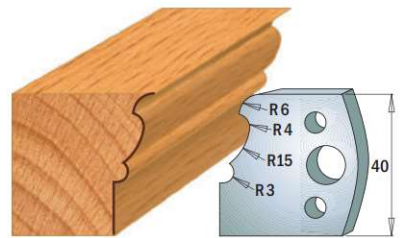

Pair of knives **690.101**
Pair of limiters **691.101**

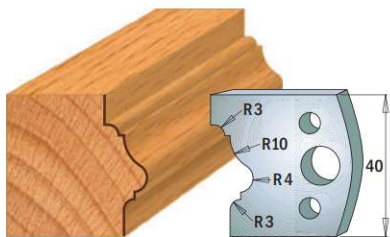

Pair of knives **690.102**
Pair of limiters **691.102**

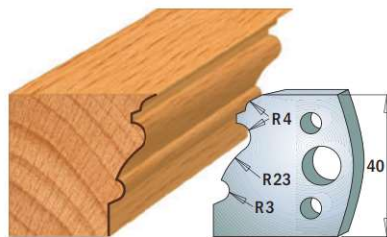

Pair of knives **690.103**
Pair of limiters **691.103**

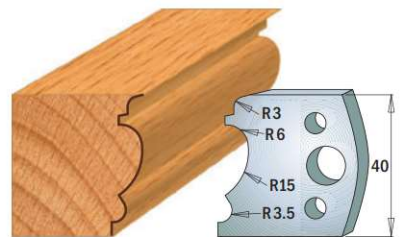

Pair of knives **690.104**
Pair of limiters **691.104**

NOTE: all knives & limiters available only in pairs

Drawings are 1:2 scale

Dimensions in mm.

Profile Knives and Limiters
Cutting Length=40mm Thickness=4mm

Pack Qty. 10

TBOX

CMT ORANGE TOOLS®

SP

Darbagaldi & Instrumenti

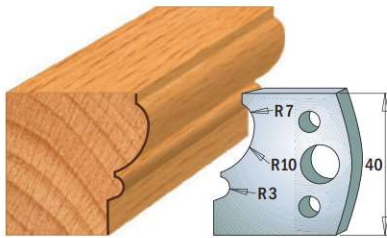

Pair of knives **690.105**
Pair of limiters **691.105**

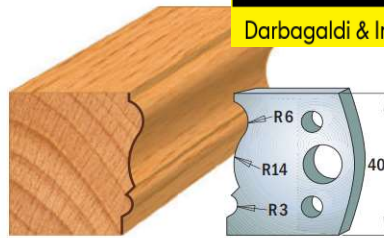

Pair of knives **690.106**
Pair of limiters **691.106**

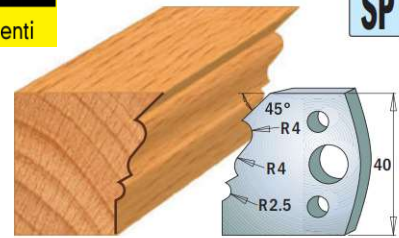

Pair of knives **690.107**
Pair of limiters **691.107**

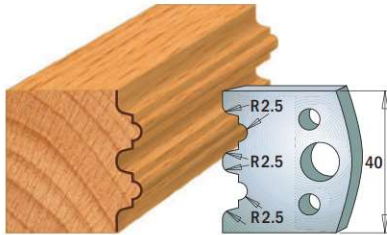

Pair of knives **690.108**
Pair of limiters **691.108**

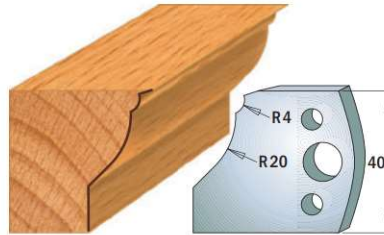

Pair of knives **690.109**
Pair of limiters **691.109**

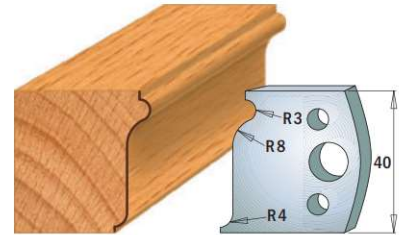

Pair of knives **690.110**
Pair of limiters **691.110**

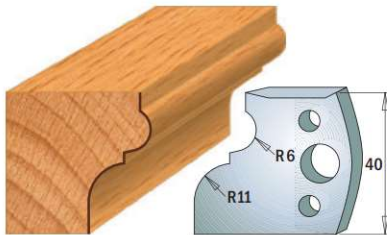

Pair of knives **690.111**
Pair of limiters **691.111**

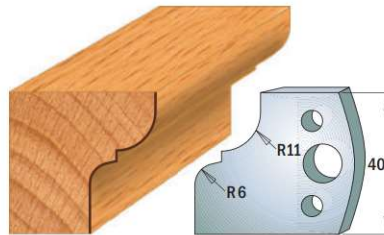

Pair of knives **690.112**
Pair of limiters **691.112**

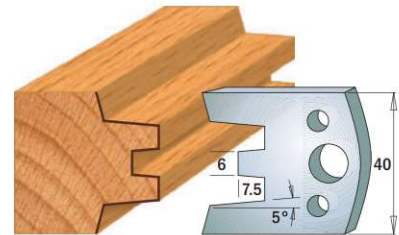

Pair of knives **690.113**
Pair of limiters **691.113**

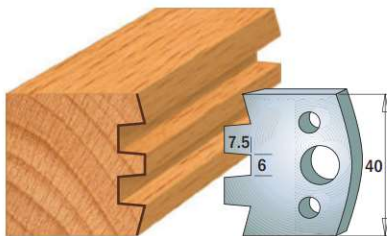

Pair of knives **690.114**
Pair of limiters **691.114**

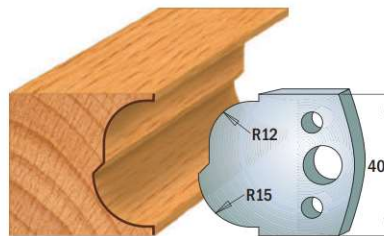

Pair of knives **690.115**
Pair of limiters **691.115**

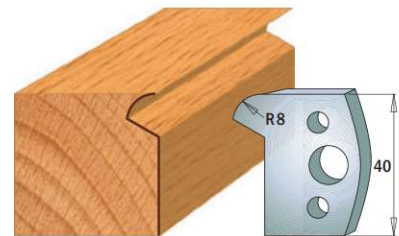

Pair of knives **690.116**
Pair of limiters **691.116**

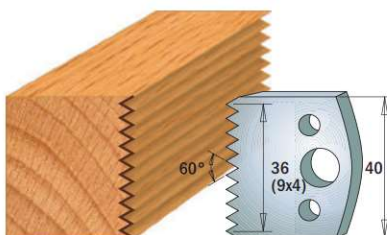

Pair of knives **690.117**
Pair of limiters **691.117**

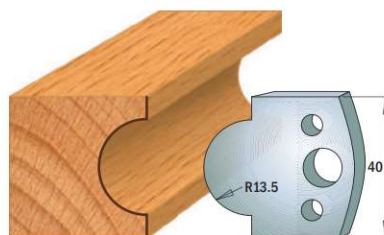

Pair of knives **690.118**
Pair of limiters **691.118**

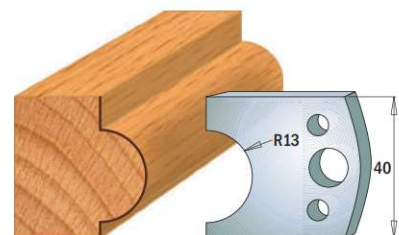

Pair of knives **690.119**
Pair of limiters **691.119**

NOTE: all knives & limiters available only in pairs

Drawings are 1:2 scale

Dimensions in mm.

Profile Knives and Limiters

Cutting Length=40mm Thickness=4mm

Pack Qty. 10



Darbagaldi & Instrumenti

SP

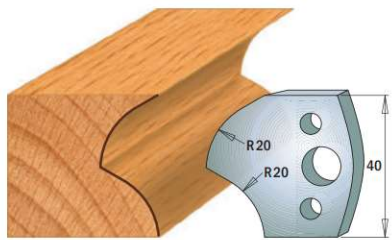

Pair of knives **690.120**
Pair of limiters **691.120**

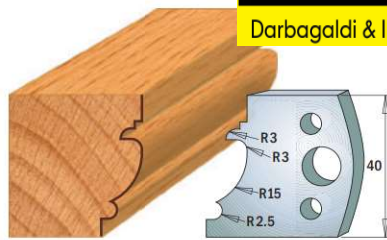

Pair of knives **690.121**
Pair of limiters **691.121**

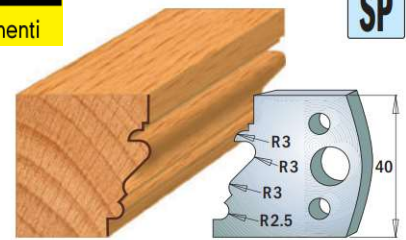

Pair of knives **690.122**
Pair of limiters **691.122**

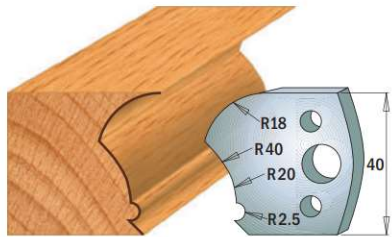

Pair of knives **690.123**
Pair of limiters **691.123**

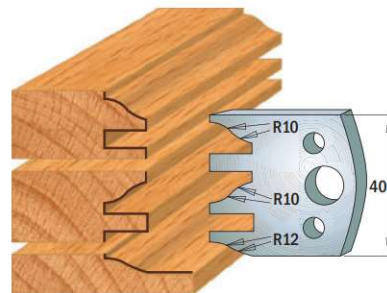

Pair of knives **690.124**
Pair of limiters **691.124**

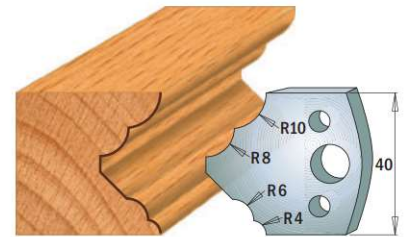

Pair of knives **690.125**
Pair of limiters **691.125**

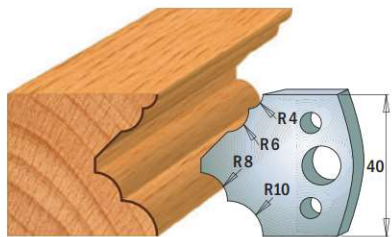

Pair of knives **690.126**
Pair of limiters **691.126**

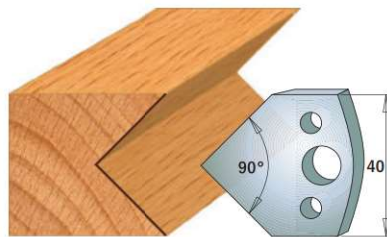

Pair of knives **690.127**
Pair of limiters **691.127**

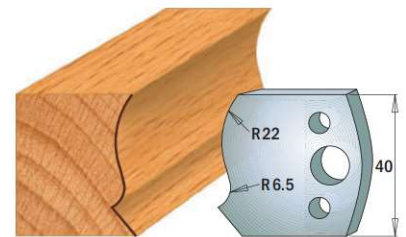

Pair of knives **690.128**
Pair of limiters **691.128**

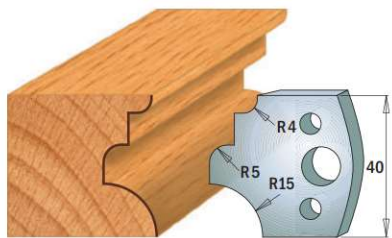

Pair of knives **690.129**
Pair of limiters **691.129**

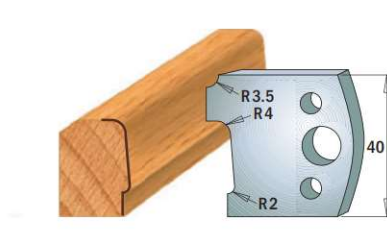

Pair of knives **690.130**
Pair of limiters **691.130**

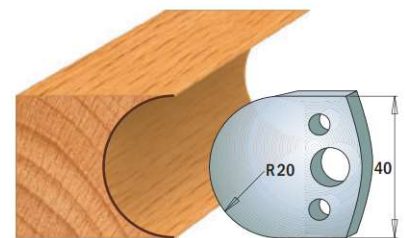

Pair of knives **690.131**
Pair of limiters **691.131**

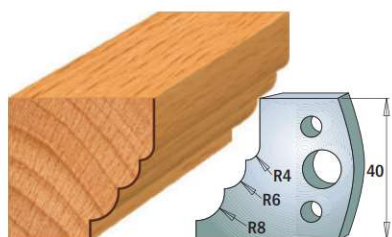

Pair of knives **690.132**
Pair of limiters **691.132**

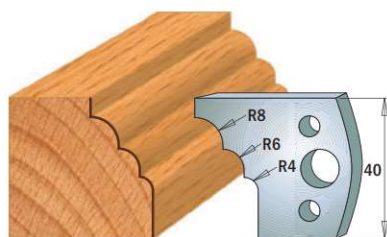

Pair of knives **690.133**
Pair of limiters **691.133**

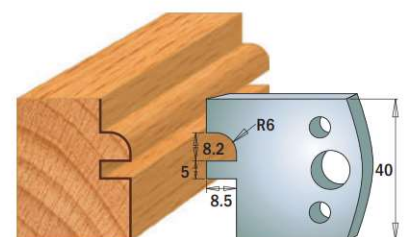

Pair of knives **690.134**
Pair of limiters **691.134**

NOTE: all knives & limiters available only in pairs

Drawings are 1:2 scale

Dimensions in mm.

Profile Knives and Limiters

Cutting Length=40mm Thickness=4mm

Pack Qty. 10



SP

Darbagaldi & Instrumenti

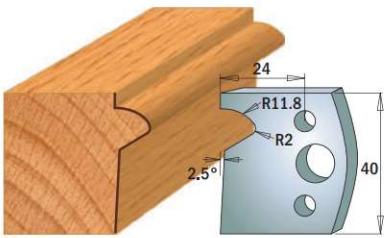

Pair of knives **690.135**
Pair of limiters **691.135**

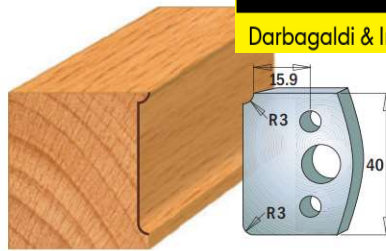

Pair of knives **690.170**
Pair of limiters **691.170**

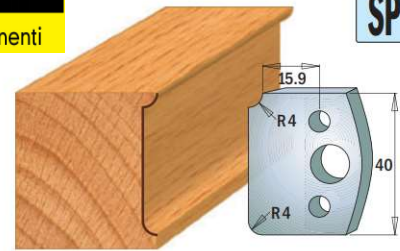

Pair of knives **690.171**
Pair of limiters **691.171**

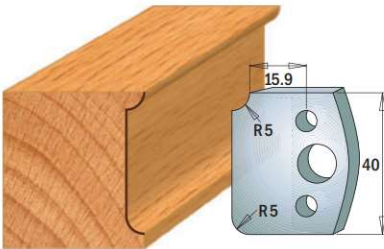

Pair of knives **690.172**
Pair of limiters **691.172**

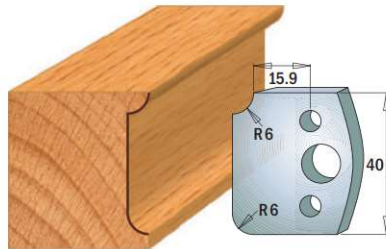

Pair of knives **690.173**
Pair of limiters **691.173**

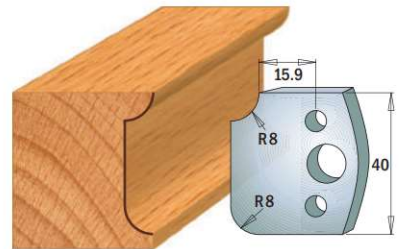

Pair of knives **690.174**
Pair of limiters **691.174**

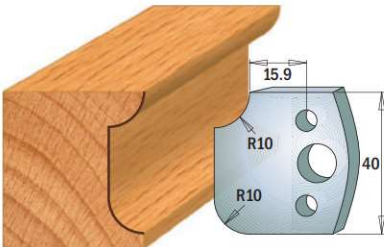

Pair of knives **690.175**
Pair of limiters **691.175**

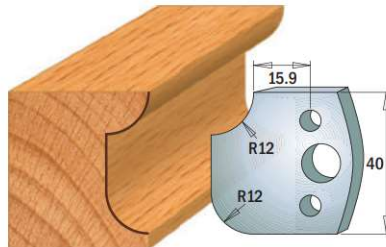

Pair of knives **690.176**
Pair of limiters **691.176**

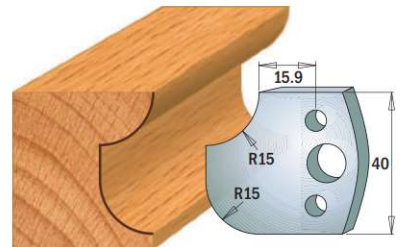

Pair of knives **690.177**
Pair of limiters **691.177**

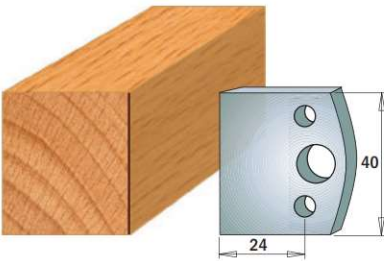

Pair of knives **690.192**
Pair of limiters **691.192**

Profile Knives and Limiters

Cutting Length=50mm

Thickness=4mm

Pack Qty. 10

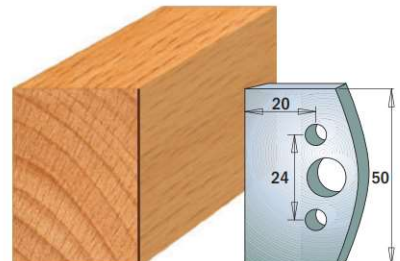

Pair of knives **690.500**
Pair of limiters **691.500**

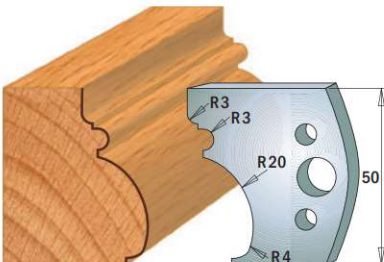

Pair of knives **690.501**
Pair of limiters **691.501**

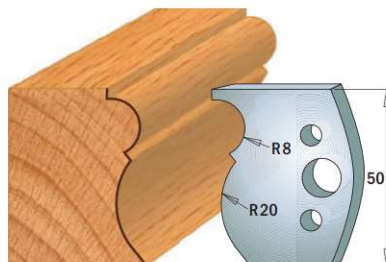

Pair of knives **690.502**
Pair of limiters **691.502**

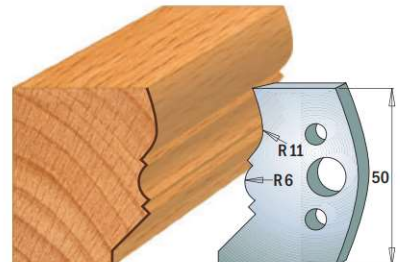

Pair of knives **690.503**
Pair of limiters **691.503**

NOTE: all knives & limiters available only in pairs

Drawings are 1:2 scale

Dimensions in mm.

Profile Knives and Limiters

Cutting Length=50mm Thickness=4mm

Pack Qty. 10

TBOX

CMT ORANGE TOOLS

Darbagaldi & Instrumenti

SP

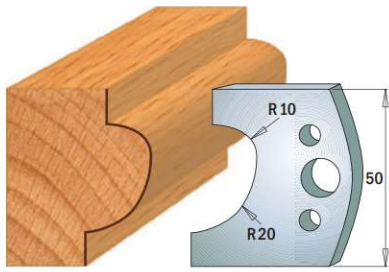

Pair of knives **690.504**
Pair of limiters **691.504**

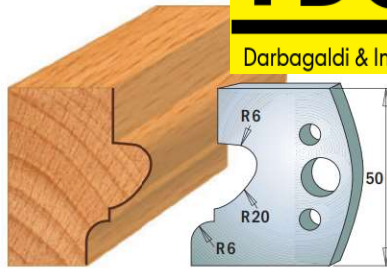

Pair of knives **690.505**
Pair of limiters **691.505**

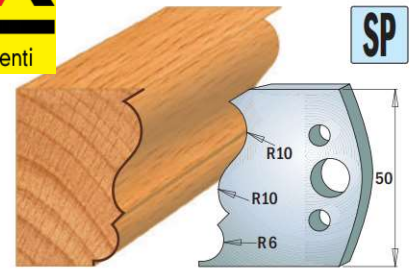

Pair of knives **690.506**
Pair of limiters **691.506**

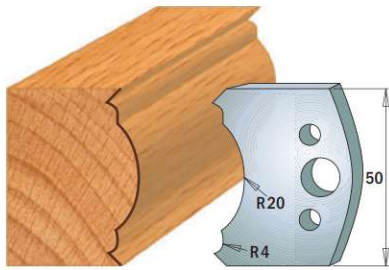

Pair of knives **690.507**
Pair of limiters **691.507**

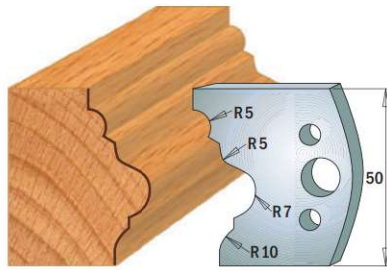

Pair of knives **690.508**
Pair of limiters **691.508**

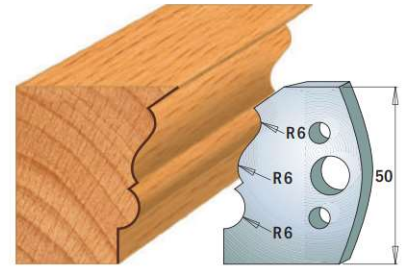

Pair of knives **690.509**
Pair of limiters **691.509**

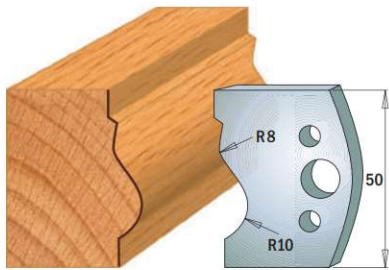

Pair of knives **690.510**
Pair of limiters **691.510**

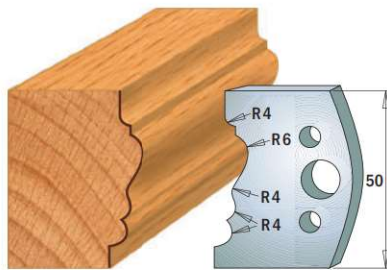

Pair of knives **690.511**
Pair of limiters **691.511**

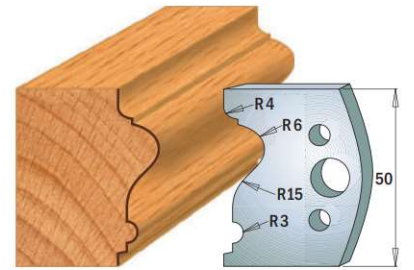

Pair of knives **690.512**
Pair of limiters **691.512**

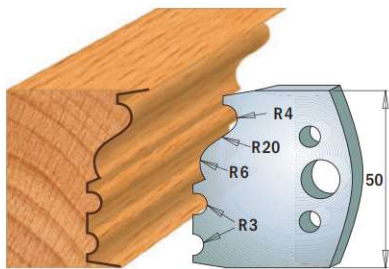

Pair of knives **690.513**
Pair of limiters **691.513**

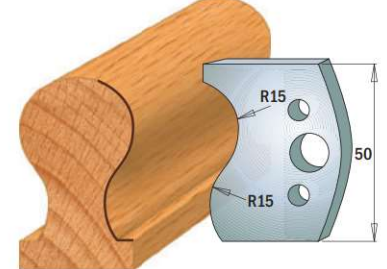

Pair of knives **690.514**
Pair of limiters **691.514**

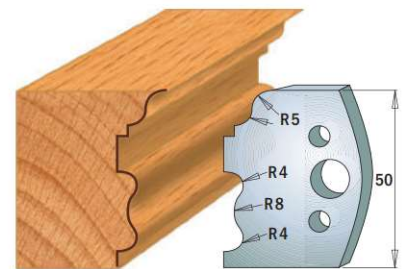

Pair of knives **690.515**
Pair of limiters **691.515**

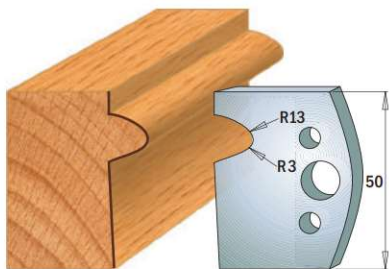

Pair of knives **690.516**
Pair of limiters **691.516**

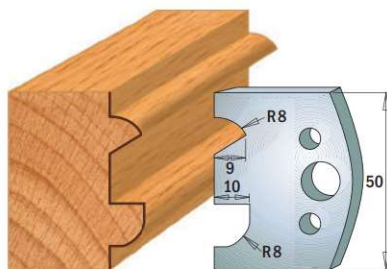

Pair of knives **690.517**
Pair of limiters **691.517**

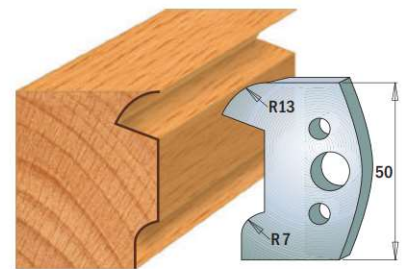

Pair of knives **690.518**
Pair of limiters **691.518**

NOTE: all knives & limiters available only in pairs

Drawings are 1:2 scale

Dimensions in mm.

Profile Knives and Limiters
Cutting Length=50mm Thickness=4mm

Pack Qty. 10

TBOX

CMT ORANGE TOOLS®

Darbagaldi & Instrumenti

SP

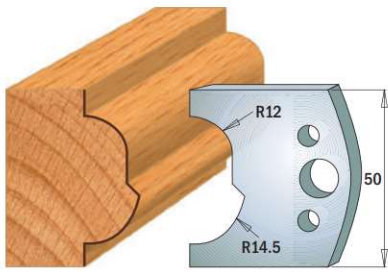

Pair of knives **690.519**
Pair of limiters **691.519**



Pair of knives **690.520**
Pair of limiters **691.520**

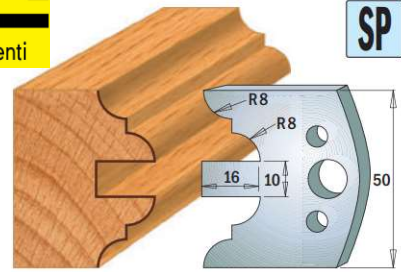

Pair of knives **690.522**
Pair of limiters **691.522**

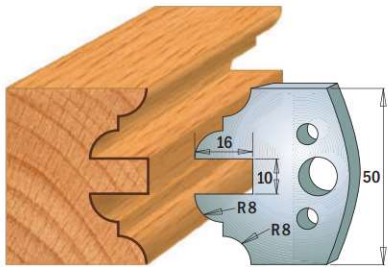

Pair of knives **690.523**
Pair of limiters **691.523**

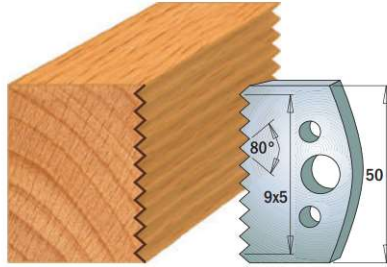

Pair of knives **690.524**
Pair of limiters **691.524**

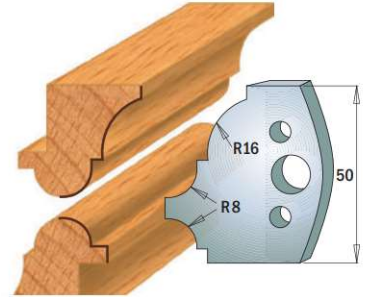

Pair of knives **690.541**
Pair of limiters **691.541**

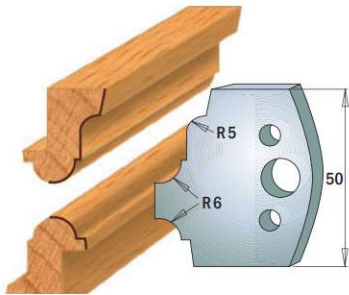

Pair of knives **690.542**
Pair of limiters **691.542**

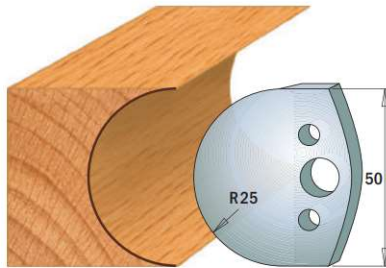

Pair of knives **690.543**
Pair of limiters **691.543**

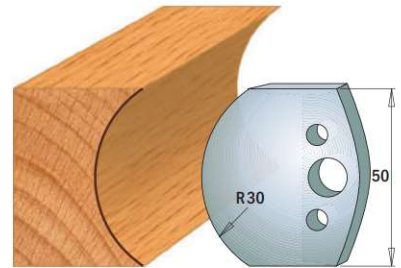

Pair of knives **690.544**
Pair of limiters **691.544**

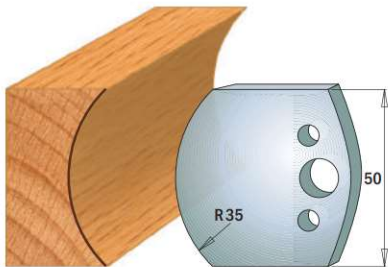

Pair of knives **690.545**
Pair of limiters **691.545**

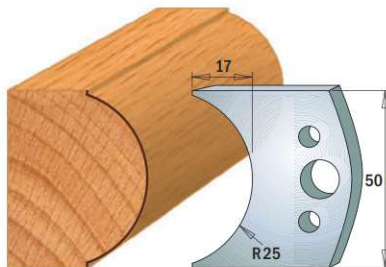

Pair of knives **690.546**
Pair of limiters **691.546**

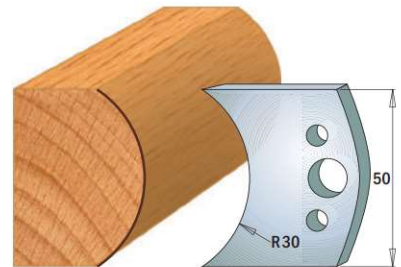

Pair of knives **690.547**
Pair of limiters **691.547**

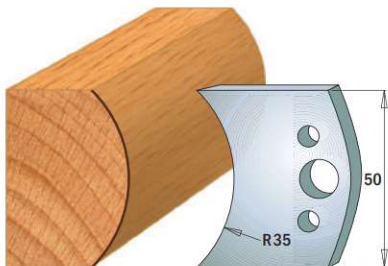

Pair of knives **690.548**
Pair of limiters **691.548**

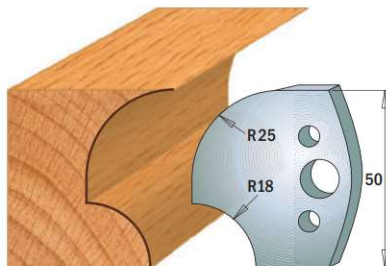

Pair of knives **690.549**
Pair of limiters **691.549**

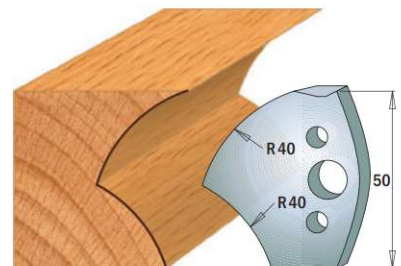

Pair of knives **690.550**
Pair of limiters **691.550**

NOTE: all knives & limiters available only in pairs

Drawings are 1:2 scale

Dimensions in mm.

Profile Knives and Limiters

Cutting Length=50mm Thickness=4mm

Pack Qty. 10



SP

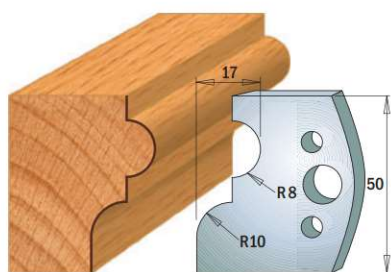

Pair of knives **690.551**
Pair of limiters **691.551**

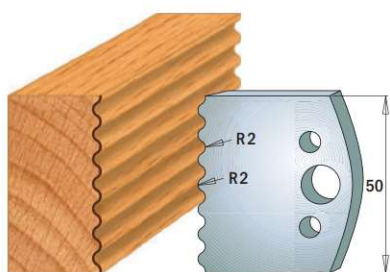

Pair of knives **690.552**
Pair of limiters **691.552**



Pair of knives **690.553**
Pair of limiters **691.553**



Pair of knives **690.554**
Pair of limiters **691.554**

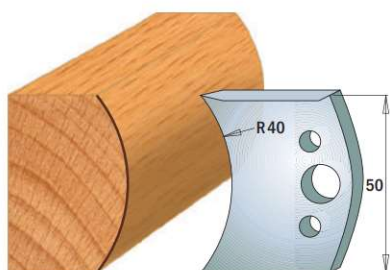

Pair of knives **690.555**
Pair of limiters **691.555**

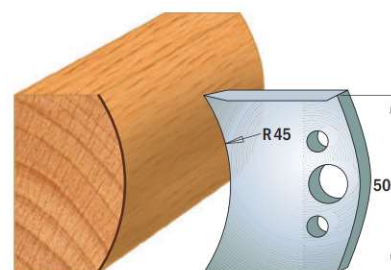

Pair of knives **690.556**
Pair of limiters **691.556**

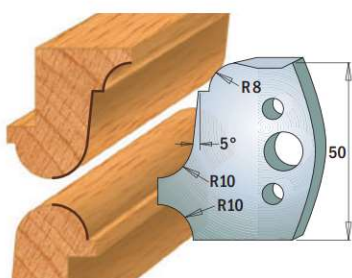

Pair of knives **690.557**
Pair of limiters **691.557**

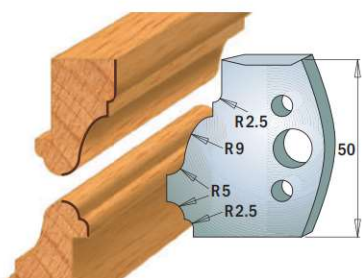

Pair of knives **690.558**
Pair of limiters **691.558**

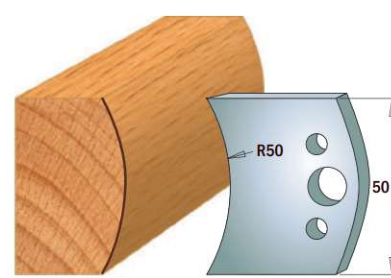

Pair of knives **690.559**
Pair of limiters **691.559**



Pair of knives **690.560**
Pair of limiters **691.560**



Pair of knives **690.561**
Pair of limiters **691.561**

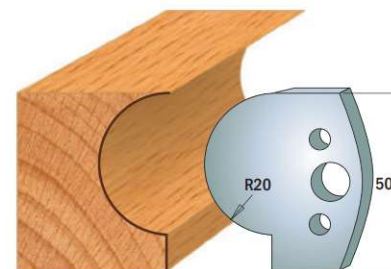

Pair of knives **690.562**
Pair of limiters **691.562**



Pair of knives **690.563**
Pair of limiters **691.563**

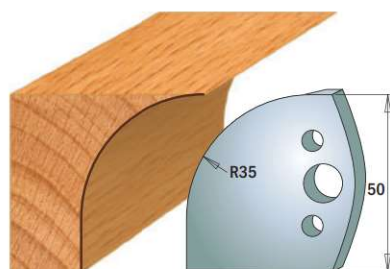

Pair of knives **690.564**
Pair of limiters **691.564**

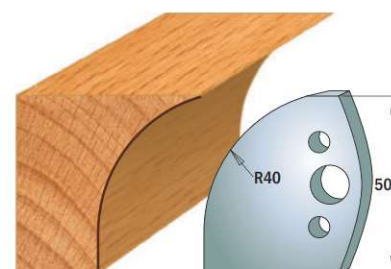

Pair of knives **690.565**
Pair of limiters **691.565**

NOTE: all knives & limiters available only in pairs

Drawings are 1:2 scale

Dimensions in mm.

Profile Knives and Limiters
Cutting Length=50mm Thickness=4mm

Pack Qty. 10



Darbagaldi & Instrumenti

SP

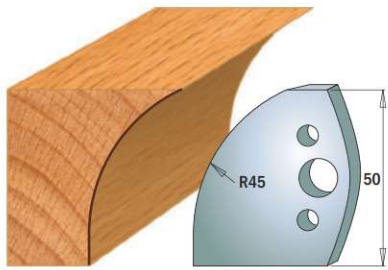

Pair of knives **690.566**
Pair of limiters **691.566**



Pair of knives **690.567**
Pair of limiters **691.567**

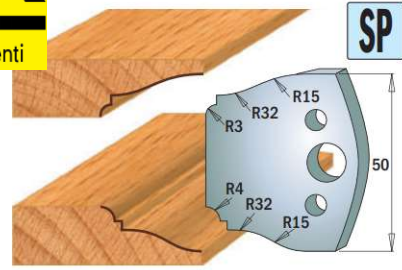

Pair of knives **690.568**
Pair of limiters **691.568**

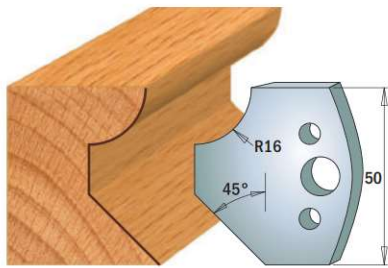

Pair of knives **690.569**
Pair of limiters **691.569**

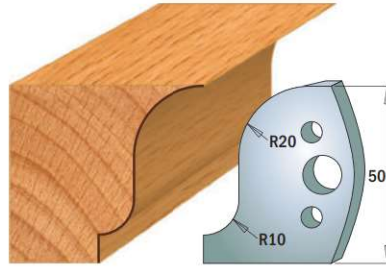

Pair of knives **690.570**
Pair of limiters **691.570**

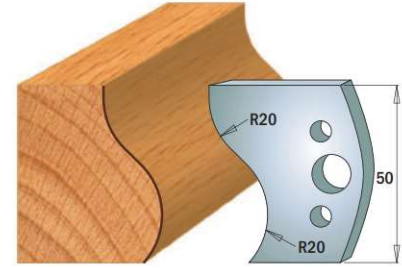

Pair of knives **690.571**
Pair of limiters **691.571**

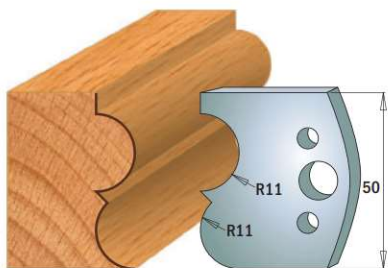

Pair of knives **690.572**
Pair of limiters **691.572**

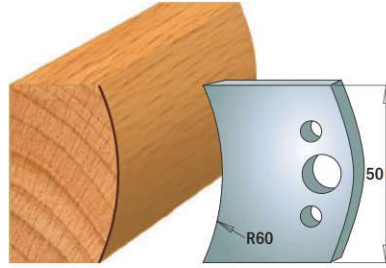

Pair of knives **690.573**
Pair of limiters **691.573**

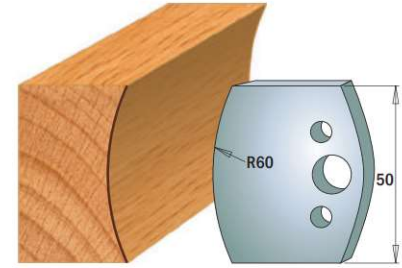

Pair of knives **690.574**
Pair of limiters **691.574**

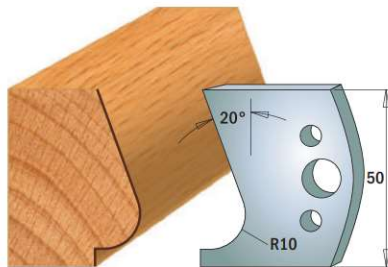

Pair of knives **690.575**
Pair of limiters **691.575**

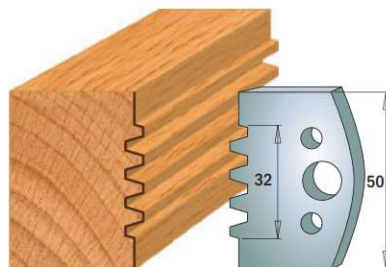

Pair of knives **690.576**
Pair of limiters **691.576**

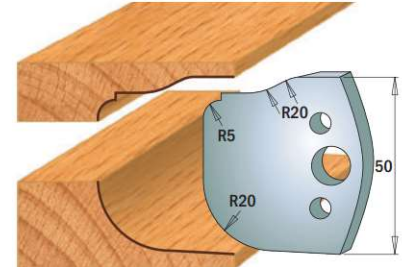

Pair of knives **690.577**
Pair of limiters **691.577**

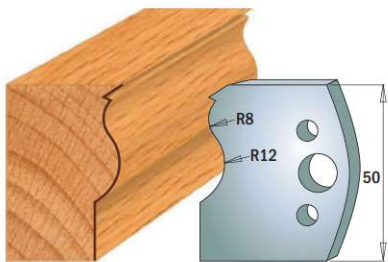

Pair of knives **690.578**
Pair of limiters **691.578**

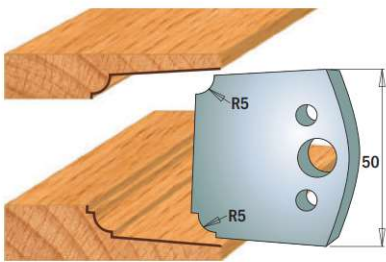

Pair of knives **690.579**
Pair of limiters **691.579**

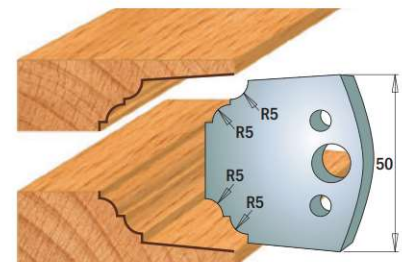

Pair of knives **690.580**
Pair of limiters **691.580**

NOTE: all knives & limiters available only in pairs

Drawings are 1:2 scale

Dimensions in mm.

Blank Knives & Limiters (to be sharpened)

Darbagaldi & Instrumenti

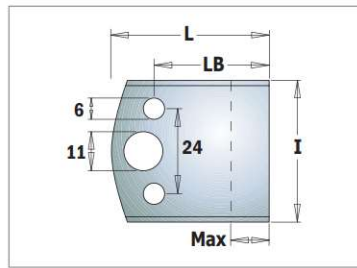

690-691

DESCRIPTION	I mm	LB mm	L mm	Max mm		ORDER NO. SP	ORDER NO. HSS
Pair of knives	40	32,5	44,5	18	10	690.193	690.193H
Pair of knives	50	34	46	20	10	690.599	690.599H
Pair of limiters	38	16	28	2	10	691.190	
Pair of limiters	38	24	36	10	10	691.192	
Pair of limiters	38	32,5	44,5	18	10		691.193
Pair of limiters	48	34	46	20	10	691.599	

Pair of Bore Reducers



699

D mm	B mm		ORDER NO.	D mm	B mm		ORDER NO.
19,05	12,7	10	699.019.13	35	32	10	699.035.32
25,4	19,05	10	699.026.19	40	30	10	699.040.30
30	19,05	10	699.030.19	40	32	10	699.040.32
30	25,4	10	699.030.26	40	35	10	699.040.35
31,75	19,05	10	699.031.19	50	30	1	699.050.30
31,75	25,4	10	699.031.26	50	32	1	699.050.32
31,75	30	10	699.031.30	50	35	1	699.050.35
35	30	10	699.035.30	50	40	1	699.050.40
35	31,75	10	699.035.31				

For use only paired.

Chucks & "ER20" Collets for Spindle Moulder Machine

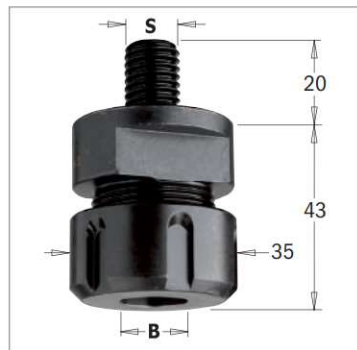

796

S mm	B mm	L mm		ORDER NO.
M12x1,75	3 ~ 12,7	43	10	796.122.00
M14x2	3 ~ 12,7	43	10	796.142.00
M16x2	3 ~ 12,7	43	10	796.162.00

Spare parts 992.483.03 M25x1,5mm clamping nut
991.483.00 "ER20" key

TECHNICAL DETAILS:
Super strength steel.
Precisely machined for accuracy.

Collet not included.

"ER20" Precision Collets for 796.122/142/162 Items



184

B mm		ORDER NO.	B mm		ORDER NO.
2	10	184.020.20	8	10	184.080.20
3	10	184.030.20	9	10	184.090.20
4	10	184.040.20	10	10	184.100.20
5	10	184.050.20	11	10	184.110.20
6	10	184.060.20	12	10	184.120.20
6,35	10	184.064.20	12,7	10	184.127.20
7	10	184.070.20			

HS Corrugated Back Moulder Knives



Darbagaldi & Instrumenti

793

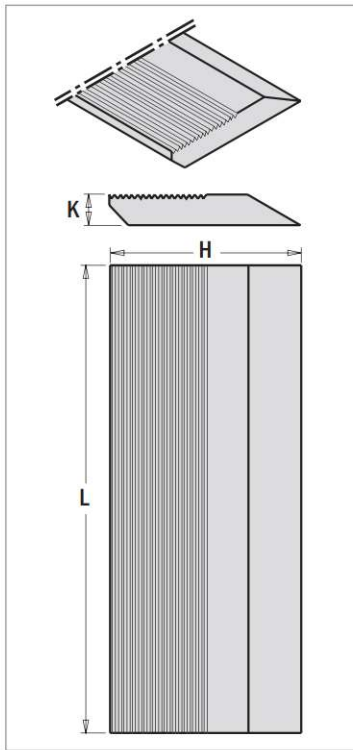

IN QUADROPACK PACKAGING
4 KNIVES FOR EACH SET

MATERIAL	HSS
Dry softwood	●
Wet softwood	●
Dry hardwood	●
Wet hardwood	○

- Suitable
- Party suitable

L mm	H mm	K mm	ORDER NO. pieces for each set		ORDER NO. HSS
40 x	50 x	8	4	1	793.040.50
40 x	60 x	8	4	1	793.040.60
40 x	70 x	8	4	1	793.040.70
60 x	50 x	8	4	1	793.060.50
60 x	60 x	8	4	1	793.060.60
60 x	70 x	8	4	1	793.060.70
80 x	50 x	8	4	1	793.080.50
80 x	60 x	8	4	1	793.080.60
80 x	70 x	8	4	1	793.080.70
100 x	50 x	8	4	1	793.100.50
100 x	60 x	8	4	1	793.100.60
100 x	70 x	8	4	1	793.100.70
120 x	50 x	8	4	1	793.120.50
120 x	60 x	8	4	1	793.120.60
120 x	70 x	8	4	1	793.120.70
130 x	60 x	8	4	1	793.130.60
130 x	70 x	8	4	1	793.130.70
650 x	40 x	8	4	1	793.650.40
650 x	50 x	8	4	1	793.650.50
650 x	60 x	8	4	1	793.650.60
650 x	70 x	8	4	1	793.650.70

REMARK: special dimensions available on request.

TECHNICAL DETAILS:
Corrugated back moulder knives for profile cutter heads with precise positioning, angle 60°, pitch 1,6mm.



Set of 2 Magnetic Knife Setting Jigs



Insert your knives into the tool holders and align them perfectly with this set! Perfect micro adjustments on will guarantee excellent cutting performance!

1. MAGNETIC STOP
2. JOINTS WITH MAGNETIC CONNECTORS
3. LOCK SCREW

CMT792

2 setup possibilities

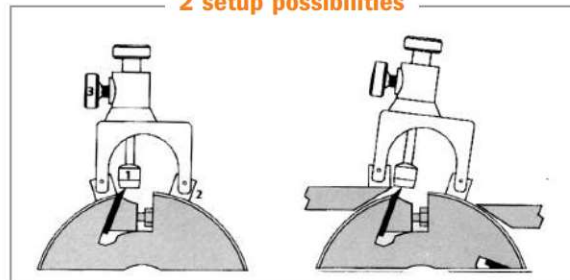

Positioning on the tool holder body with detection of the knife position.

Direct positioning on both the planer table and the tool holder body with detection of the knife position.

DESCRIPTION		ORDER NO.
Set of 2 magnetic knife setting jigs	25	CMT792

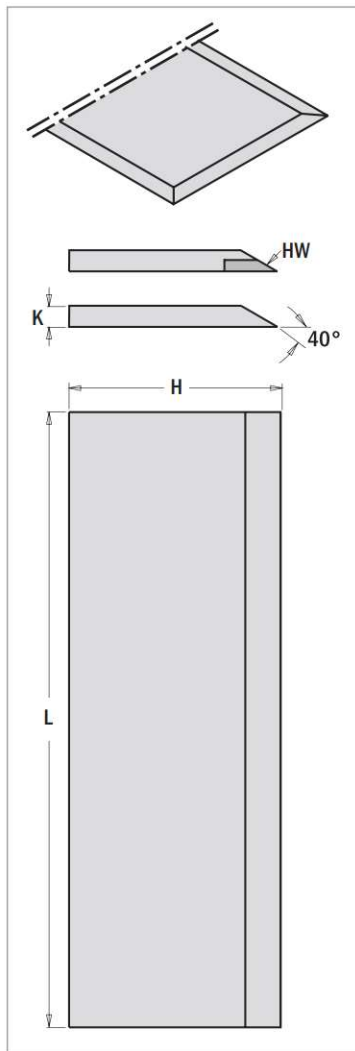

IN QUADROPACK PACKAGING
2 KNIVES FOR EACH SET

792

L mm	H mm	K mm	KNIVES pieces for each set		ORDER NO. SP	ORDER NO. HSS*	ORDER NO. HW
120 x 30 x 3			2	1		792.120.30	
130 x 30 x 3			2	1	792.131.30	792.130.30	792.132.30
150 x 30 x 3			2	1		792.150.30	
180 x 30 x 3			2	1	792.181.30	792.180.30	792.182.30
200 x 30 x 3			2	1	792.201.30	792.200.30	
210 x 30 x 3			2	1	792.211.30	792.210.30	
230 x 30 x 3			2	1	792.231.30	792.230.30	792.232.30
250 x 30 x 3			2	1	792.251.30	792.250.30	792.252.30
260 x 30 x 3			2	1	792.261.30	792.260.30	792.262.30
300 x 30 x 3			2	1	792.301.30	792.300.30	792.302.30
310 x 30 x 3			2	1	792.311.30	792.310.30	792.312.30
350 x 30 x 3			2	1	792.351.30	792.350.30	792.352.30
400 x 30 x 3			2	1	792.401.30	792.400.30	792.402.30
410 x 30 x 3			2	1	792.411.30	792.410.30	792.412.30
430 x 30 x 3			2	1	792.431.30	792.430.30	792.432.30
450 x 30 x 3			2	1	792.451.30	792.450.30	792.452.30
500 x 30 x 3			2	1	792.501.30	792.500.30	792.502.30
510 x 30 x 3			2	1	792.511.30	792.510.30	792.512.30
520 x 30 x 3			2	1	792.521.30	792.520.30	792.522.30
530 x 30 x 3			2	1	792.531.30	792.530.30	792.532.30
600 x 30 x 3			2	1	792.601.30	792.600.30	792.602.30
610 x 30 x 3			2	1	792.611.30	792.610.30	792.612.30
630 x 30 x 3			2	1	792.631.30	792.630.30	792.632.30
640 x 30 x 3			2	1		792.640.30	
710 x 30 x 3			2	1		792.710.30	
810 x 30 x 3			2	1	792.811.30	792.810.30	792.812.30
1050 x 30 x 3			2	1	792.998.30	792.997.30	792.999.30
300 x 35 x 3			2	1		792.300.35	
310 x 35 x 3			2	1	792.311.35		
350 x 35 x 3			2	1	792.351.35	792.350.35	
400 x 35 x 3			2	1	792.401.35	792.400.35	
410 x 35 x 3			2	1	792.411.35	792.410.35	
430 x 35 x 3			2	1		792.430.35	
450 x 35 x 3			2	1	792.451.35	792.450.35	
500 x 35 x 3			2	1	792.501.35	792.500.35	
510 x 35 x 3			2	1	792.511.35	792.510.35	
520 x 35 x 3			2	1	792.521.35	792.520.35	
530 x 35 x 3			2	1	792.531.35	792.530.35	
550 x 35 x 3			2	1	792.551.35	792.550.35	
600 x 35 x 3			2	1	792.601.35	792.600.35	
610 x 35 x 3			2	1	792.611.35	792.610.35	
630 x 35 x 3			2	1	792.631.35	792.630.35	
650 x 35 x 3			2	1	792.651.35	792.650.35	
710 x 35 x 3			2	1		792.710.35	
810 x 35 x 3			2	1	792.811.35	792.810.35	
820 x 35 x 3			2	1	792.821.35		
1050 x 35 x 3			2	1	792.998.35	792.997.35	

* The HSS knives are balanced and milled.

MATERIAL	SP	HSS	HW
Dry softwood	○	●	
Wet softwood	○	○	
Dry hardwood	○	●	●
Wet hardwood	○	●	○
Chipboard			○
MDF			○
Glulam		○	●
Solid surface			○

- Suitable
- Party suitable

REMARK: special dimensions available on request.

The mirror finish on HW knives produces both razor sharp and extremely durable cutting edges.



TERSA

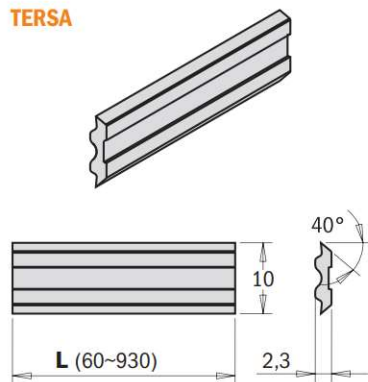

**CENTROSTAR
CENTROFIX
QUICKFIX**

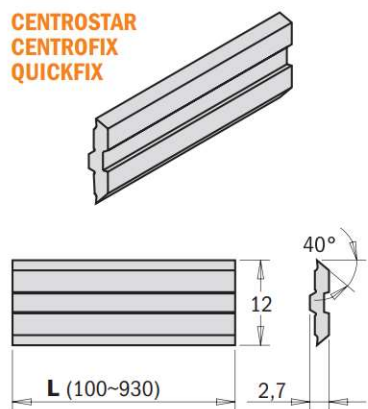

CENTROLOCK

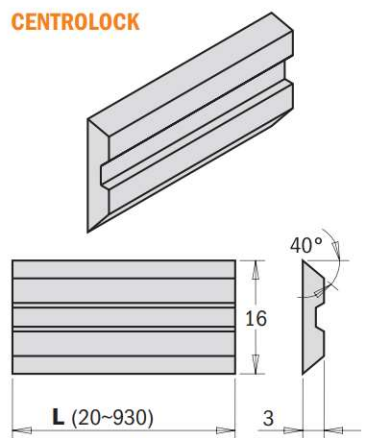

2 KNIVES FOR EACH SET

MATERIAL	GOOD	EXCELLENT
Dry Softwood		●
Wet Softwood		●
Dry Hardwood		●
Wet Hardwood		●
Exotic Hardwood	●	

795

Darbagaldi & Instrumenti

TERSA				CENTROSTAR, CENTROFIX, QUICKFIX				CENTROLOCK			
L	H	K	ORDER NO.	L	H	K	ORDER NO.	L	H	K	ORDER NO.
mm	mm	mm		mm	mm	mm		mm	mm	mm	
80 x 10 x 2,3			795.080.10*					20 x 16 x 3			795.020.16*
100 x 10 x 2,3			795.100.10	100 x 12 x 2,7			795.100.12*	80 x 16 x 3			795.080.16*
110 x 10 x 2,3			795.110.10	110 x 12 x 2,7			795.110.12*				
120 x 10 x 2,3			795.120.10	120 x 12 x 2,7			795.120.12				
130 x 10 x 2,3			795.130.10	130 x 12 x 2,7			795.130.12	130 x 16 x 3			795.130.16
150 x 10 x 2,3			795.150.10	150 x 12 x 2,7			795.150.12	150 x 16 x 3			795.150.16
				160 x 12 x 2,7			795.160.12*				
170 x 10 x 2,3			795.170.10	170 x 12 x 2,7			795.170.12*	170 x 16 x 3			795.170.16
180 x 10 x 2,3			795.180.10	180 x 12 x 2,7			795.180.12	180 x 16 x 3			795.180.16
				190 x 12 x 2,7			795.190.12*	190 x 16 x 3			795.190.16
				200 x 12 x 2,7			795.200.12*				
210 x 10 x 2,3			795.210.10					210 x 16 x 3			795.210.16
				220 x 12 x 2,7			795.220.12*				
230 x 10 x 2,3			795.230.10	230 x 12 x 2,7			795.230.12	230 x 16 x 3			795.230.16
								235 x 16 x 3			795.235.16*
				240 x 12 x 2,7			795.240.12	240 x 16 x 3			795.240.16
250 x 10 x 2,3			795.250.10								
260 x 10 x 2,3			795.260.10					260 x 16 x 3			795.260.16
				270 x 12 x 2,7			795.270.12*	270 x 16 x 3			795.270.16
				280 x 12 x 2,7			795.280.12*				
300 x 10 x 2,3			795.300.10								
310 x 10 x 2,3			795.310.10	310 x 12 x 2,7			795.310.12	310 x 16 x 3			795.310.16
330 x 10 x 2,3			795.330.10*								
350 x 10 x 2,3			795.350.10	350 x 12 x 2,7			795.350.12*				
				360 x 12 x 2,7			795.360.12*				
400 x 10 x 2,3			795.400.10	400 x 12 x 2,7			795.400.12				
410 x 10 x 2,3			795.410.10	410 x 12 x 2,7			795.410.12				
420 x 10 x 2,3			795.420.10	420 x 12 x 2,7			795.420.12*				
430 x 10 x 2,3			795.430.10	430 x 12 x 2,7			795.430.12*				
450 x 10 x 2,3			795.450.10	450 x 12 x 2,7			795.450.12*				
500 x 10 x 2,3			795.500.10								
510 x 10 x 2,3			795.510.10	510 x 12 x 2,7			795.510.12				
520 x 10 x 2,3			795.520.10	520 x 12 x 2,7			795.520.12				
530 x 10 x 2,3			795.530.10	530 x 12 x 2,7			795.530.12*				
540 x 10 x 2,3			795.540.10								
610 x 10 x 2,3			795.610.10	610 x 12 x 2,7			795.610.12				
				620 x 12 x 2,7			795.620.12				
630 x 10 x 2,3			795.630.10	630 x 12 x 2,7			795.630.12				
635 x 10 x 2,3			795.635.10								
640 x 10 x 2,3			795.640.10	640 x 12 x 2,7			795.640.12				
650 x 10 x 2,3			795.650.10	650 x 12 x 2,7			795.650.12*				
710 x 10 x 2,3			795.710.10	710 x 12 x 2,7			795.710.12*				
				810 x 12 x 2,7			795.810.12*				
860 x 10 x 2,3			795.860.10*								
910 x 10 x 2,3			795.910.10*								
930 x 10 x 2,3			795.930.10	930 x 12 x 2,7			795.930.12*	930 x 16 x 3			795.930.16

*While supplies last

TECHNICAL DETAILS:

HPS® was specially developed for the woodworking industry. The Thyssen-Krupp heat treatment division developed a special heat treatment system in a modern vacuum oven which gives this steel its special attributes and renders it an outstanding alternative to HSS steel. The main advantages are:

- superb wear resistance
- maximum level of toughness
- easy to profile
- long lasting tested
- resistance to softening

Test result: Wood=Oak, Spinadle speed=6000 rpm, feed=24 meter/min
 = Result HPS® 17500 meters.
 = Result HSS 10000 meters.



790

	L mm	H mm	K mm	A	Z	ORDER NO. K1920	ORDER NO. K2250
	7,5	12	1,5	35°	2	790.075.00	
7,65	12	1,5	35°	2	790.076.00		
9,6	12	1,5	35°	2	790.096.00		
15	12	1,5	35°	2	790.150.00		
19,5	12	1,5	4/35°	2	790.195.12		
20	12	1,5	35°	2	790.200.00	790.200.03	

	L mm	H mm	K mm	A	Z	ORDER NO. K1920	ORDER NO. K2250
	24,7	12	1,5	35°	2	790.250.00	
30	12	1,5	35°	2	790.300.00	790.300.03	
30	12	1,5	45°	2	790.300.20		
40	12	1,5	35°	2	790.400.00	790.400.03	
50	12	1,5	35°	2	790.500.00	790.500.03	
60	12	1,5	35°	2	790.600.00	790.600.03	

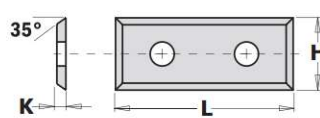
	L mm	H mm	K mm	A	Z	ORDER NO. K1920	
	29,5	9	1,5	35°	4	790.295.09	
29,5	12	1,5	35°	4	790.295.12		
39,5	9	1,5	35°	4	790.395.09		
39,5	12	1,5	35°	4	790.395.12		
49,5	9	1,5	35°	4	790.495.09		
49,5	12	1,5	35°	4	790.495.12		

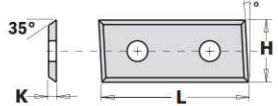
	L mm	H mm	K mm	A	Z	ORDER NO. K1920	
	28,3	12	1,5	35°	4	790.283.12	
48,3	12	1,5	35°	4	790.483.12		

	L mm	H mm	K mm	A	Z	ORDER NO. K1920	ORDER NO. K2250
	10,5	10,5	1,5	35°	4		790.105.03
12	12	1,5	35°	4	790.120.00	790.120.03	
13,6	13,6	2	30°	4	790.136.00		
14	14	1,2	30°	4	790.140.10		
14	14	2	30°	4	790.140.00	790.140.03	
14	14	2	45°	4	790.140.02		

	L mm	H mm	K mm	A	Z	ORDER NO. K1920	
	12	12	1,5	30°	4	790.120.20	
14	14	2	30°		790.140.20		

	L mm	H mm	K mm	R mm	A	Z	ORDER NO. K1920	
	15	15	2,5	115	30°	4	790.152.12	
15	15	2,5	150	30°	4	790.152.22		

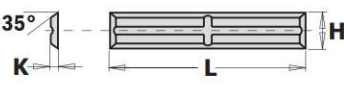
	L mm	H mm	K mm	A	Z	ORDER NO. K1920	
	20	4,1	1,1	35°	4	790.200.01	
30	5,5	1,1	35°	4	790.300.01		
50	5,5	1,1	35°	4	790.500.01		

790

Darbagaldi & Instrumenti



	L mm	H mm	K mm	A	Z	ORDER NO. K1920
	50	9	1,5	35°	4	790.500.09

	L mm	H mm	K mm	B	A	Z	ORDER NO. K1920
	20	12	1,5	1	35°	2	790.201.00
	30	12	1,5	2	35°	2	790.301.00
	50	12	1,5	2	35°	2	790.501.00

	L mm	H mm	K mm	Z	ORDER NO. K1920
	18	18	1,95	4	790.181.00
	18	18	2,45	4	790.182.00

	L mm	H mm	K mm	A	Z	ORDER NO. K1920
	22	19	2	30°	3	790.220.02

	L mm	H mm	K mm	A	Z	ORDER NO. K1920
	28	14	2	30°	2	790.280.00

	L mm	H mm	K mm	R mm	A	Z	ORDER NO. K1920
	16	22	5	1,5			790.161.00
	16	22	5	2			790.162.00
	16	22	5	3			790.163.00
	16	22	5		45°		790.160.00

	L mm	H mm	K mm	R mm	A	Z	ORDER NO. K1920
	19,5	9	1,5	2	35°	2	790.020.00
	19,5	9	1,5	3	35°	2	790.030.00
	19,5	9	1,5	5	35°	2	790.050.00
	24	12	1,5	6,4	35°	2	790.064.00
	24	12	1,5	8	35°	2	790.080.00

	L mm	H mm	K mm	A	Z	ORDER NO. DP
	30	12	1,5	35°	1	790.300.60*

*These knives are supplied in a 2 pc. case. Minimum 2 pieces or multiple of 2 piece order.

MATERIAL	K1920	K2250
Softwood	★★★★	
Hardwood	★★★★★	
Chipboard	★★★★★	★★★★★
MDF	★★★★	★★★★★
HDF	★★★★	★★★★★
Plastics	★★★	★★★★★
Solid Surface		★★★★

TECHNICAL DETAILS:

K1920 Hardness (HV10): 1.920 - Transverse rupture strength (N/mm2): 2.600
New chrome grade for universal cutting applications. Excellent resistance to corrosion, oxidation and mechanical wear. High efficiency, 20% longer lifetime compared to standard grade.

K2250 Hardness (HV10): 2.250 - Transverse rupture strength (N/mm2): 2.400
New nano-grain grade for maximum wear resistance. Higher efficiency due to improved tool lifetime. Improved toughness.

All knives are supplied in a 10 pc. case.
Minimum 10 piece or multiple of 10 piece order.



HWM Reversible Knives for Portable Planers



Darbagaldi & Instrumenti

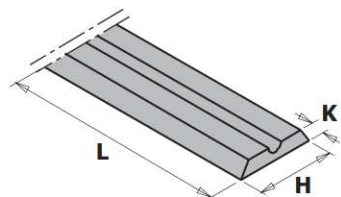

10-pcs. CASE (minimum order)



2-pcs. BLISTER CASE
(790.755/790.780/790.806/790.805/790.820)



2-pcs. BLISTER CASE

790

L mm	H mm	K mm	MACHINE	MODEL MACHINE	ORDER NO. 2-pcs. blister case	ORDER NO. 10-pcs. blister case
56	5,5	1,1	Adler			790.560.00
60	5,5	1,1	Wegoma			790.600.01
75,5	5,5	1,1	Aeg	HTH75	790.755	790.755.00
			Black & Decker	DN75, 750SR, 600K		
			Bosch	0590, P400, 1590, 1591		
			Festool	REP75		
			Haffner	FH222		
			Holz-Her	2223, 2286, 2320		
			Kress	Jet-Star 6701, 6702		
			Mafell	HU75		
			Metabo	6375		
			Scheer	MH75/3, MH80		
			Skil	98H		
78	5,5	1,1	Virutex		790.780	790.780.00
80,5	5,9	1,2	Elu	MFF40, MFF80, MFF81, MFF81EK, PF161	790.806	790.805.00
80,5	5,5	1,1	Elu Aeg, Bosch Haffner	MFF80	790.805	790.805.01
82	5,5	1,1	Aeg	EH82, EH825, EH822, EH450, EH700, EH82-1, H500, H750, EH700R	790.820	790.820.00
			Black & Decker	DN76		
			Bosch	PHO 100/150, PHO 200/300 4387, PHO 2-82/3-82, Gustav, H00882		
			Casals	CE82		
			DeWalt	DW678, DW678EK, DW680		
			Elu	HH15, HH40, HH40K, HH40EK		
			Fein	HS2151		
			Felisatti	TP282		
			Haffner	FH224		
			Hitachi	F20, F20A, FP20A, P20V, P20SA		
			Holz-Her	2321, 2322		
			Legna	R82, G82		
			Mafell	EHU82, MHU82		
			Makita	1001, 1100, 1125B, 1900B, 1901, 1923B, 1923H, 1923HO		
			Metabo	4382, 8382, 0882, 0883, E0983		
			Peerles	HHB82B		
			Peugeot	RA400, 82RAC, RA82CS, BR82 BRA1-82, BRA3-82, RA1082CA		
			Ryobi	L1323-A		
			Skil	H92, H94, H95, H96, H97 1506, 1510		
			Stayer	980B		
92	5,5	1,2	Aeg	450		790.920.00
			Hitachi	F30A, FU30		
			Ryobi	L120N, L150N, L1205N, L1323		
102	5,5	1,1	Aeg	HB750, EH102, HBE800		790.992.00

L mm	H mm	K mm	MACHINE	MODEL MACHINE	ORDER NO. 2-pcs. HSS	ORDER NO. 2-pcs. HW
82	29	3	Bosch	GH020-82	790.821.50	790.821.10
			B&D	DN710, DB711		
			Makita	1900B, 1923B, 1100, 1901 1125		
			Ryobi	L-1323A, L-282		
new	110	29	3	Makita	1002BA, 1911B	790.110.50

TECHNICAL DETAILS:

- Order no. ISO: K40
- Hardness (HV10): 1.400
- Transverse rupture strength (N/mm²): 2.600

APPLICATION:

- Softwood Good
- Hardwood Suitable
- Plywood Suitable